

OWNERS MANUAL

how to maintain and operate your
EcoWater electronic demand water system

.....



SERIES
3000, 3002
and 3200

WITH **DC** (direct current) VALVE
DRIVE **MOTOR**

NOTE: Refer to manual # 7101580 for
information on all models with an **AC**
(alternating current) valve drive motor.

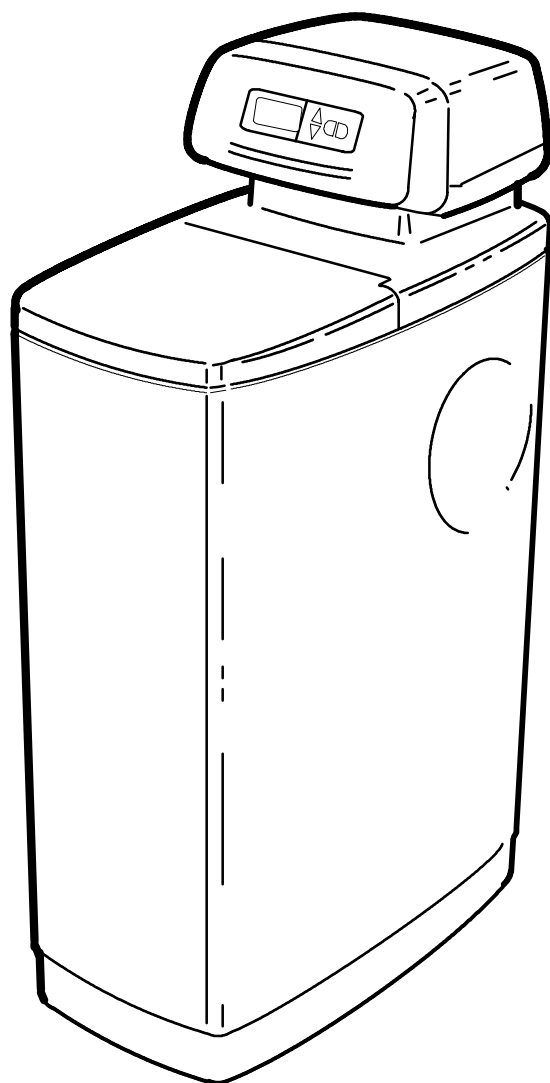

UNPACKING

EcoWater Systems units, Series 3000 and 3002, Models R20 and R30, are shipped from the factory in 1 master carton, consisting of resin tank, brine tank and controller. The carton also includes a skin pack of small parts needed to assemble and install the unit, and this manual.

Series 3000 and 3002, Models R40 and R70 are shipped in 2 cartons. These contain:

- brine tank, controller and covers, skin-pack of small parts, owners manual
- resin tank assembly

Thoroughly check the Eco System unit for possible shipping damage and parts loss. Also inspect and note any damage to the shipping carton(s). Notify the transportation company if damage is present. EcoWater is not responsible for in-transit damages.

Remove and discard (RECYCLE) all packing materials. We suggest you keep the small parts on the skin-pack until you are ready to use them. Minimal assembly is needed on all models...see page 7.

TABLE OF CONTENTS

	Page
Warranty	3
Dimensions	4
Water / Water Conditioning	5-6
Assembly	7
Planning Installation	8-9
Installation Steps	10-15
Programming Face Plate-Timer	14-15
Features / Options	15-18
Extra Recharges (Regenerations)	16
Eco System Unit Operation	19-22
Electronics	19
Service / Regeneration / Water Flow	19-22
Service Information	23-27
Refilling with Salt	23
Troubleshooting	25-27
Wiring Schematic	32
Repair Parts	28-31

SAFETY GUIDES

FOLLOW THE INSTALLATION INSTRUCTIONS CAREFULLY. FAILURE TO INSTALL THE ECO SYSTEM UNIT PROPERLY VOIDS THE WARRANTY.

BEFORE YOU BEGIN INSTALLATION, READ THIS ENTIRE MANUAL. THEN, OBTAIN ALL THE MATERIALS AND TOOLS YOU WILL NEED TO MAKE THE INSTALLATION.

CHECK LOCAL PLUMBING AND ELECTRICAL CODES. THE INSTALLATION MUST CONFORM TO THEM.

USE ONLY LEAD-FREE SOLDER AND FLUX FOR ALL SWEAT-SOLDER CONNECTIONS, AS REQUIRED BY STATE AND FEDERAL CODES.

USE CARE WHEN HANDLING THE ECO SYSTEM UNIT. DO NOT TURN UPSIDE DOWN, DROP, OR SET ON SHARP PROTRUSIONS.

DO NOT LOCATE THE ECO SYSTEM UNIT WHERE FREEZING TEMPERATURES OCCUR. DO NOT ATTEMPT TO TREAT WATER OVER 120°F. **FREEZING, OR HOT WATER DAMAGE VOIDS THE WARRANTY.**

AVOID INSTALLING IN DIRECT SUNLIGHT. EXCESSIVE SUN HEAT MAY CAUSE DISTORTION OR OTHER DAMAGE TO NON-METALLIC PARTS.

THE ECO SYSTEM REQUIRES A MINIMUM WATER FLOW OF 3 GALLONS PER MINUTE AT THE INLET. **MAXIMUM ALLOWABLE INLET WATER PRESSURE IS 125 PSI.** IF DAYTIME PRESSURE IS OVER 80 PSI, NIGHTTIME PRESSURE MAY EXCEED THE MAXIMUM. USE A PRESSURE REDUCING VALVE IF NECESSARY. (ADDING A PRESSURE REDUCING VALVE MAY REDUCE THE FLOW.)

THE ECO SYSTEM UNIT WORKS ON 24 VOLT-60 Hz ELECTRICAL POWER ONLY. BE SURE TO USE THE INCLUDED TRANSFORMER.

WARRANTY

EcoWater Systems, Inc.
Advantage Warranty
Series 3000 E/D Water System

EcoWater Systems, Inc., guarantees to the original owner, that:

1. ...for the **lifetime of the original owner**, the *salt tank* and the *fiberglass mineral tank* will not rust, corrode, leak, burst, or in any other manner fail to perform their proper functions; and that
2. ...for a period of **five (5) years after installation**, the *electronic computer control panel*, the *valve body*, and *all other parts* will be free from defects in material and workmanship, and will perform their normal functions.

Series 3000 E/D WATER REFINER models only, designated as + PLUS on the rating decal: The *EcoLife™* resin is also guaranteed, for the lifetime of the original owner, to remove chlorine from a municipal water supply.

If during such respective period a part proves, after inspection by EcoWater, to be so defective, EcoWater will, at its sole option, either replace or repair the part without charge except normal shipping and installation charges. Labor necessary to maintain this equipment is limited to one (1) year.

General Provisions

The above warranties are effective provided the water conditioner is operated at water pressures not exceeding 125 psi, and at water temperatures not exceeding 120°F (and on a municipal chlorinated water supply - *models designated as + PLUS on the rating decal*); provided further that the water conditioner is not subject to abuse, misuse, alteration, neglect, freezing, accident or negligence; and provided further that the water conditioner is not damaged as the result of any unusual force of nature such as, but not limited to, flood, hurricane, tornado or earthquake. EcoWater Systems, Inc., is excused if failure to perform its warranty obligations is the result of strikes, government regulation, materials shortages, or other circumstances beyond its control.

To obtain warranty service, notice must be given, within thirty (30) days of the discovery of the defect, to your local EcoWater Systems dealer.

THERE ARE NO WARRANTIES ON THE WATER CONDITIONER BEYOND THOSE SPECIFICALLY DESCRIBED ABOVE. ALL IMPLIED WARRANTIES, INCLUDING ANY IMPLIED WARRANTY OF MERCHANTABILITY OR OF FITNESS FOR A PARTICULAR PURPOSE, ARE DISCLAIMED TO THE EXTENT THEY MIGHT EXTEND BEYOND THE ABOVE PERIODS. THE SOLE OBLIGATION OF ECOWATER SYSTEMS, INC. UNDER THESE WARRANTIES IS TO REPLACE OR REPAIR THE COMPONENT OR PART WHICH PROVES TO BE DEFECTIVE WITHIN THE SPECIFIED TIME PERIOD, AND ECOWATER IS NOT LIABLE FOR CONSEQUENTIAL OR INCIDENTAL DAMAGES. NO ECOWATER DEALER, AGENT, REPRESENTATIVE, OR OTHER PERSON IS AUTHORIZED TO EXTEND OR EXPAND THE WARRANTIES EXPRESSLY DESCRIBED ABOVE.

Some states do not allow limitations on how long an implied warranty lasts or exclusions or limitations of incidental or consequential damage, so the limitations and exclusions in this warranty may not apply to you. This warranty gives you specific legal rights, and you may have other rights which vary from state to state. This warranty applies to consumer-owned installations only.

GUARANTEE
BOND

The Continental Casualty Company, an Illinois corporation, has issued its bond in the form shown below, guaranteeing full performance by EcoWater Systems, Inc.

CONTINENTAL CASUALTY COMPANY, Chicago, Illinois, hereinafter called "Surety," guarantees unto Harris Trust and Savings Bank, 111 West Monroe Street, Chicago, Illinois, as Trustee holding said Guarantee Bond under the terms of a Trust Agreement dated September 15, 1963, for the use and benefit of original purchasers of residential EcoWater Systems Units within the Continental United States, as described herein, that EcoWater Systems, Inc., will discharge the obligations of the "EcoWater Bonded Parts and Service Guarantee Policy."

PROVIDED, HOWEVER, that:

1. Liability of Surety hereunder shall not exceed the sum of FIVE HUNDRED AND 00/100th DOLLARS (\$500.00) as to any one installation, and shall not exceed the sum of FIVE HUNDRED THOUSAND AND 00/100th DOLLARS (\$500,000.00) in the aggregate, and
2. There shall be no liability hereunder as to any purchaser to whom there has not been issued at the time of installation and purchase completed registration card which is enclosed with a facsimile of this bond, and who has not returned such card in accordance with this guarantee.
3. Claim must be made by such original purchaser in writing within 30 days from the expiration of these guarantees upon EcoWater Systems, Inc., PO Box 64420, St. Paul, MN 55164, to perform the terms of said guarantee, and notice of any default on such guarantee must be sent to Surety at its address by Registered Mail.

CONTINENTAL CASUALTY COMPANY

attest: 
assistant secretary

by: 
vice-president

This is to certify that the original of the above guarantee and bond is on file with Harris Trust and Savings Bank, 111 West Monroe Street, Chicago, Illinois.

HARRIS TRUST AND SAVINGS BANK
As Trustee

by: 
authorized officer

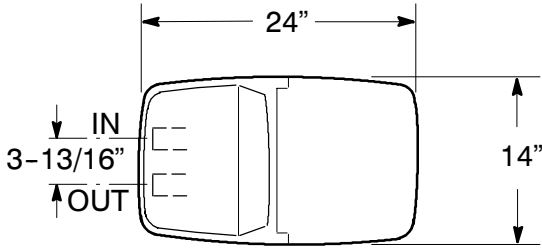

NOTE: See the product brochure for operating specifications.

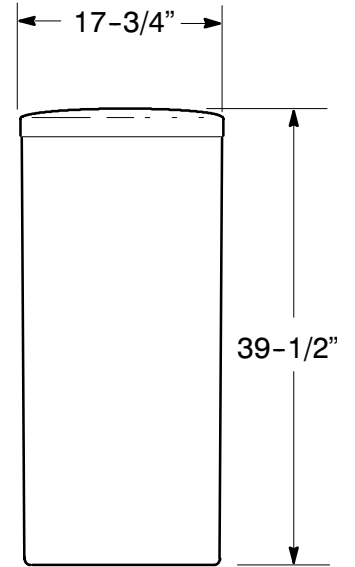
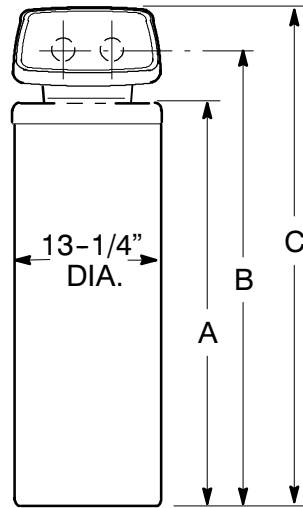
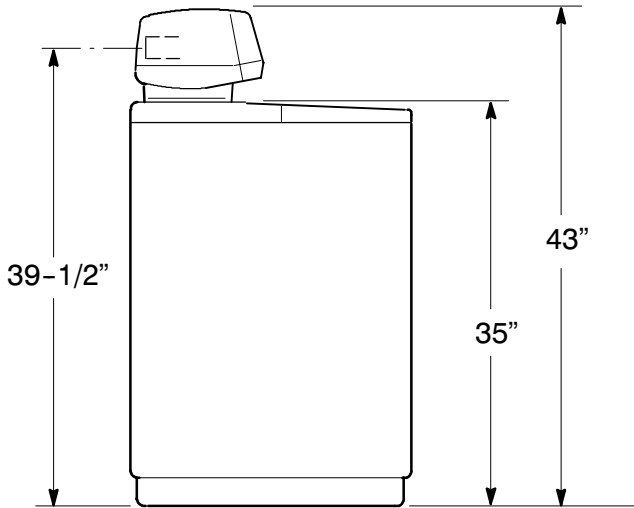

SALT STORAGE CAPACITIES

■ *Round* Brine Tank - 300 lbs

■ *Rectangular* Brine Tank

Freestanding - 400 lbs

Tank-in-tank - 300 lbs

MODEL	NOMINAL RESIN TANK SIZE	A	B	C
R20	8" DIA. X 35"	35"	39.5"	43"
R30 R20 Plus	10" DIA. X 35"	35"	39.5"	43"
R40 R30 Plus	10" DIA. X 47"	47"	51.3"	55"
R70	12" DIA. X 54"	53"	57.3"	61"

FOR FUTURE REFERENCE, ENTER THE FOLLOWING INFORMATION

MODEL NO. ①② _____ SERIAL NO. ①② _____
 DATE CODE ② _____ INSTALLATION DATE _____
 WATER HARDNESS _____ GPG IRON CONTENT _____ PPM
 WATER HARDNESS SETTING _____ (see page 15)

① on rating decal ② on shipping carton



WATER

Man's very existence depends on water. It is 1 of the basic commodities of life. Water is best as nature provides it, is a common misconception. Practically all natural water needs refinement or treatment to make it safe to drink or more satisfactory to use.

The earth's water supply cycle starts in the upper cloud layers. As it falls to the earth as rain or snow, it picks up impurities and gases from the atmosphere. Landing on earth, it seeps over and through the ground, dissolving earth minerals. Passing through limestone, it dissolves calcium and magnesium, the hardness minerals. Iron deposits impart iron to the water. Acidity and sediments are other water conditions.

Municipal water supplies come from surface reservoirs, such as lakes and rivers, or from underground reservoirs. Usually, municipalities chlorinate the water to make it safe to drink. Sediment is removed by filtration. Tastes and odors are reduced or eliminated. The water is conditioned to comply with certain specifications. However, hardness minerals, tastes and odors are not always reduced to the most desirable levels.

Underground reservoirs provide our private water supplies. Because the water is raw and untreated, it can have varying amounts of hardness, iron, tastes, odors, acidity, or combinations of these. Different localities and water levels affect mineral content.

WATER CONDITIONING

Water conditioning is the treatment of 4 general conditions. These are: (1) *Hardness*, (2) *Iron*, (3) *Acidity*, (4) *Sediments*.

(1) **HARDNESS** is a term to describe the presence of calcium and magnesium minerals in water. A chemical analysis accurately measures the amount of minerals in grain weight. For example, 1 gallon of water with 5 grains per gallon (gpg) hardness has dissolved minerals, that if solidified, about equals the size of 1 ordinary aspirin tablet. One gallon of water, 25 gpg hard, has a mineral content equal in size to 5 aspirin tablets. Water hardness varies greatly across the country. It generally contains from 3 to 100 gpg.

Hard water affects living in general. Hardness minerals combine with soap to make a soap curd. The curd greatly reduces the cleaning action of soap. Precipitated hardness minerals form a crust on cooking utensils, appliances, and plumbing fixtures. Even the tastes of foods are affected. A water softener removes the hardness minerals to eliminate these problems, and others. Pages 19-22 describe how the Eco System Unit works.

Sodium Information: Water softeners using sodium chloride (salt) for regeneration add sodium to the water. Persons on sodium restricted diets should consider the added sodium as part of their overall intake.

(2) **IRON** in water is measured in parts per million (ppm). The total* ppm of iron, and type or types*, is determined by chemical analysis. Four different types of iron in water are: ❶ Ferrous (clear water), ❷ Ferric (red water), ❸ Bacterial and organically bound iron, ❹ Colloidal and inorganically bound iron (ferrous or ferric).

*Water may contain 1 or more of the 4 types of iron and any combination of these. Total iron is the sum of the contents.

❶ **Ferrous (clear water)** iron is soluble and dissolves in water. It is usually detected by taking a sample of water in a clear bottle or glass. Immediately after taking, the sample is clear. As the water sample stands, it gradually clouds and turns slightly yellow or brown as air oxidizes the iron. This usually occurs in 15 to 30 minutes. An Eco System Unit will remove moderate amounts of this type of iron (see specifications).

❷ **Ferric (red water)**, and ❸ **Bacterial and organically bound irons** are insoluble. This iron is visible immediately when drawn from a faucet because it has oxidized before reaching the home. It appears as small cloudy yellow, orange, or reddish suspended particles. After the water stands for a period of time, the particles settle to the bottom of the container. Generally these irons are removed from water by filtration. Chlorination is also recommended for bacterial iron. An Eco System Unit will remove minimal quantities (see specifications) of ferric iron.

continued



④ Colloidal and inorganically bound iron is of ferric or ferrous form that will not filter or exchange out of water. In some instances, treatment may improve colloidal iron water, but always CONSULT A QUALIFIED WATER CHEMISTRY LAB before attempting to treat it. Colloidal iron water usually has a yellow appearance when drawn. After standing for several hours, the color persists and the iron does not settle, but remains suspended in the water.

Iron in water causes stains on clothing and plumbing fixtures. It negatively affects the taste of food, drinking water, and other beverages.

(3) *ACIDITY* or acid water is caused by carbon dioxide, hydrogen sulfide, and sometimes industrial

wastes. It is corrosive to plumbing, plumbing fixtures, water heaters, and other water using appliances. It can also damage and cause premature failure of seals, diaphragms, etc., in water handling equipment.

A chemical analysis is needed to measure the degree of acidity in water. This is called the pH of water. Water testing below 6.9 pH is acidic. The lower the pH reading, the greater the acidity. A neutralizer filter or a chemical feed pump are usually recommended to treat acid water.

(4) *SEDIMENT* is fine, foreign material particles suspended in water. This material is most often clay or silt. Extreme amounts of sediment may give the water a cloudy appearance. A sediment filter normally corrects this condition.



R20 / R30 RECTANGULAR MODELS TANK - IN - TANK

1. Be sure the brinewell is correctly located, held at top and bottom by the brine tank (FIG. 1). Remove the brinewell cover and check the brine valve to be sure the float stem is vertical to the brine valve body.
2. Orient the valve and resin tank, as desired, relative to the brine tank (FIG. 2).
3. **CONNECT BRINE TUBING:** Looking at FIG. 1, route the brine tubing under the covers, around and behind the resin tank. Open 1 of the “break-away” holes in the rear cover and pass the tubing through it. Connect to the nozzle assembly, using the small screen and nut-ferrule included on the skin-pack. Tighten the nut by hand, then another 1/4 turn with a pliers. *Also see FIG. 9, on page 11.*

RECTANGULAR AND ROUND “FREE-STANDING” BRINE TANKS

1. Locate the brinewell in position. On a round brine tank, locate the slots, at the bottom of the brinewell, toward the tank wall as shown in FIG. 3. Then, use the screw and nut (on skin-pack) to fasten the brinewell in place.
2. Lower the brine valve into the brinewell. Push the tubing into the brinewell top slot (FIG. 1 or 3), and route out of the brine tank...
... through the larger hole in the round tank sidewall.
... through 1 of the “break-away” holes in the rear cover, toward the backside of the valve, on a rectangular tank, FIG. 1.
3. Install the brinewell cover.



**R40 / R70 RESIN TANK AND
CONTROLLER**

1. Unclamp and remove the shipping cap from the resin tank (FIG. 4).
2. BE SURE ALL O-RING SEALS ARE IN PLACE, then position the valve on the resin tank, over the bottom distributor standpipe.

3. Push down on the valve while installing the 2 clamps and clamp retainers. **Be sure the retainers are locked in place.**

ALL MODELS

Install the brine tank overflow grommet and elbow in the 3/4" dia. hole, in the brine tank sidewall (FIG. 1 or 3).

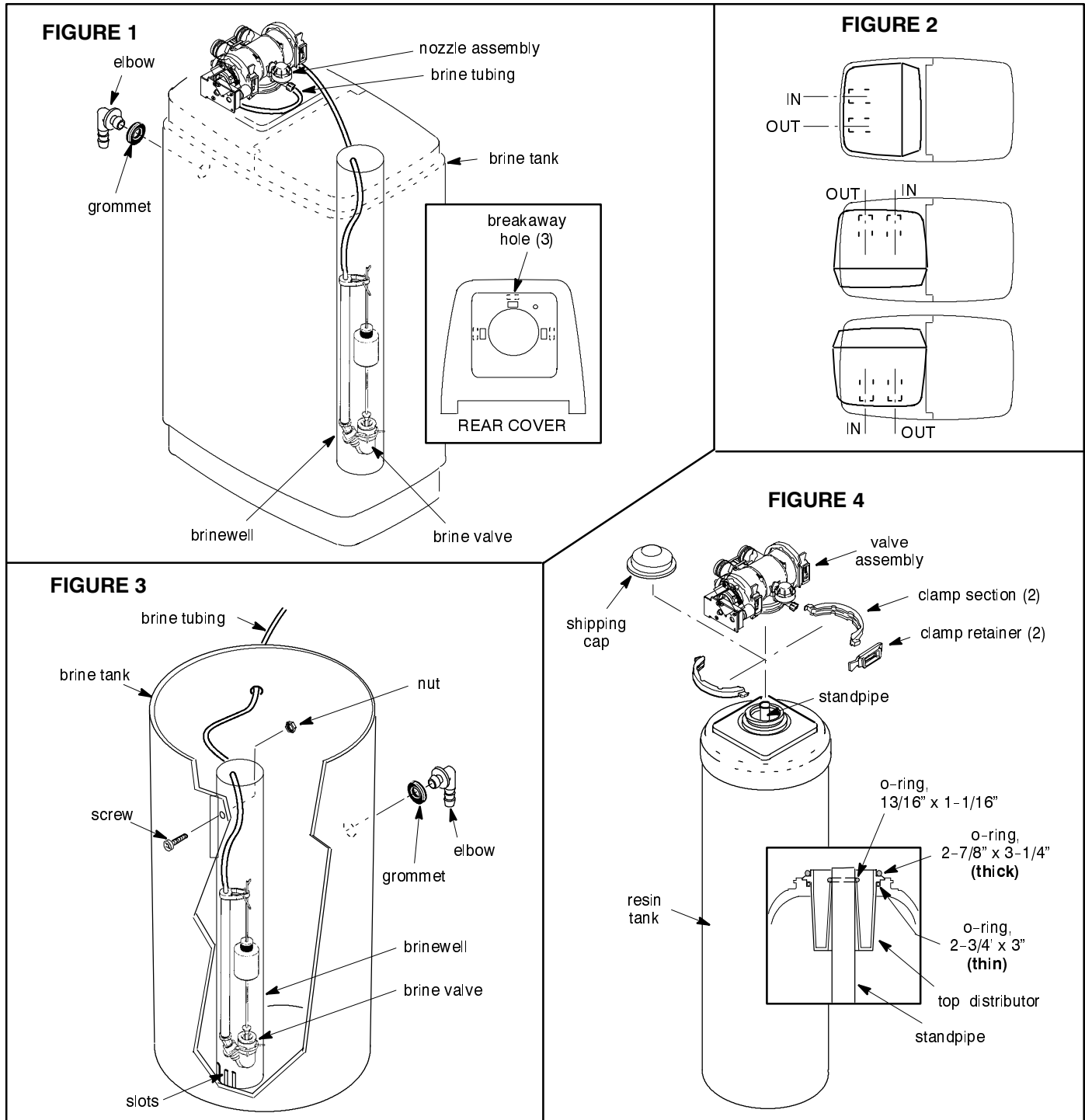

TYPICAL INSTALLATION DRAWINGS

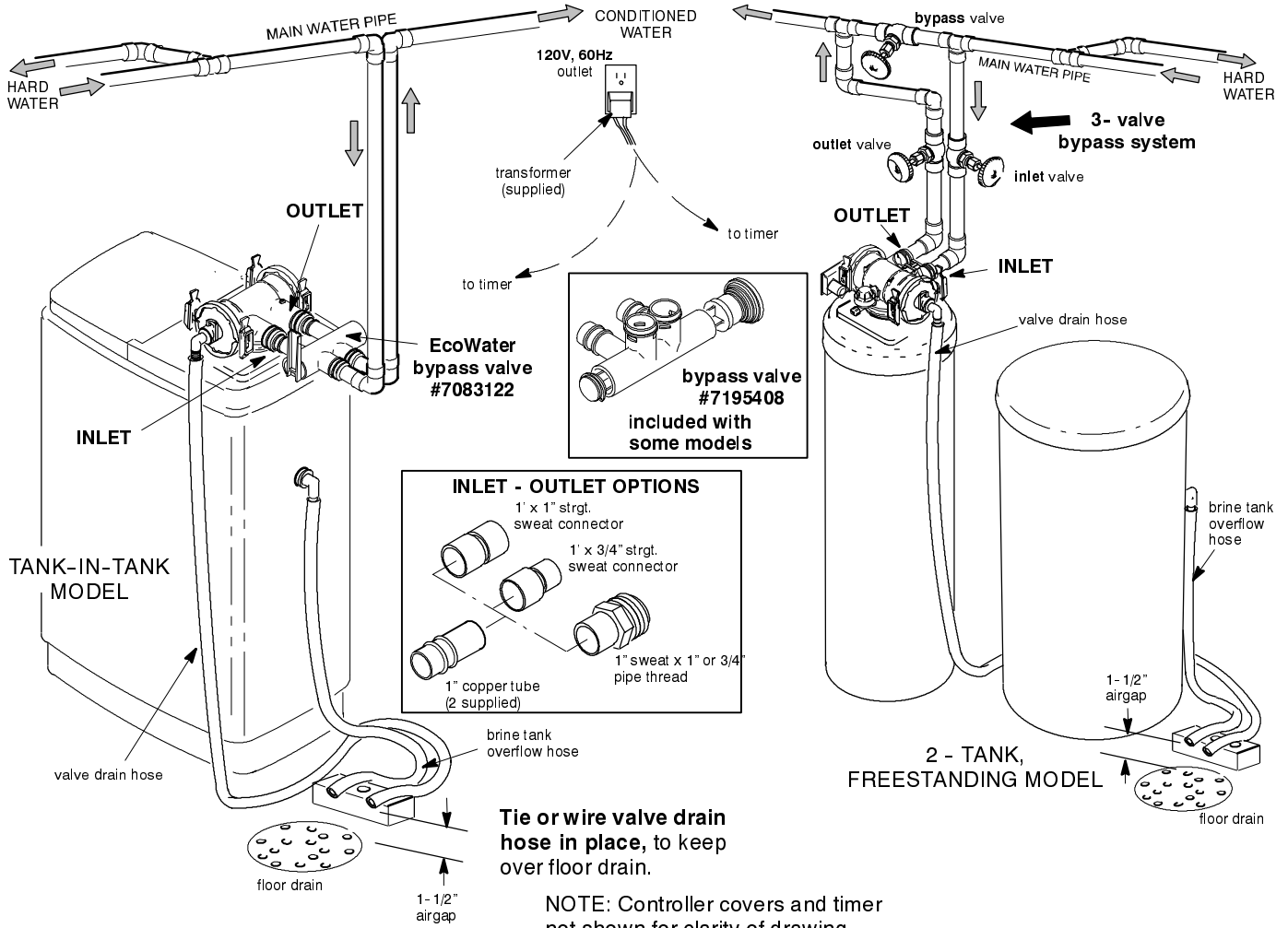

INLET - OUTLET PLUMBING OPTIONS

- ALWAYS INSTALL 1 of the EcoWater bypass valves, #7083122 or #7195408 (included with some models), or a 3 valve bypass system. Bypass valves allow you to turn of water to the softener for repairs if needed, but still have water in house pipes.
- Use 1"... or, 3/4" (minimum) pipe and fittings.
- Use sweat copper... or, threaded pipe*... or, CPVC plastic pipe.*

*Sweat soldering is required to adapt to the fittings (1" male) supplied with the EcoWater System Unit, or obtain approved compression adaptors. PVC plastic adaptors, part #7104546, are available from EcoWater. **Be sure to comply with all local plumbing codes.**

OTHER REQUIREMENTS

- A drain is needed for regeneration discharge water. A floor drain is preferred, close to the Eco System Unit. A laundry tub, sump, standpipe, etc., are other drain options.

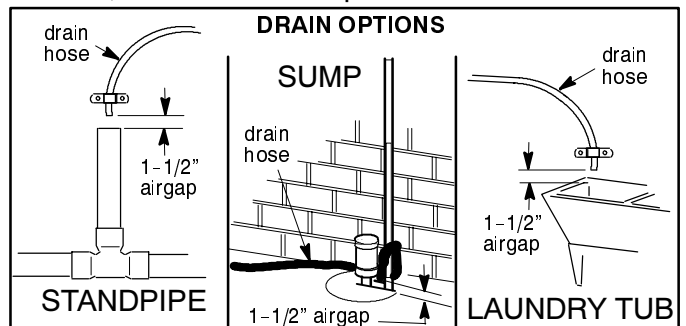

- a 120V-60Hz, grounded electrical outlet (continuously "live") is needed within 10' of the Eco System Unit.

TOOLS YOU MAY NEED

- common screwdriver
- cross-point screwdriver
- pliers
- tape measure

SOLDERED COPPER THREADED CPVC PLASTIC

- | | | |
|--|--------------------------|---------------------|
| • tubing cutter | • hacksaw or pipe cutter | • hacksaw |
| • propane torch | • threading tool | • adjustable wrench |
| • LEAD-FREE solder and flux | • pipe joint compound* | • solvent cement* |
| • emery cloth, sandpaper or steel wool | | • primer |

MATERIALS YOU MAY NEED

- bypass valve (included with some models), or 3 valves
- pipe and fittings as required
- 1/2" I. D. high quality, flexible hose for the valve drain*, and brine tank drain (The brine tank drain elbow accepts either 1/2" or 3/8" I. D. hose.)

* VALVE DRAIN OPTIONS: Flexible drain hose is not allowed in all localities (check your codes). For a rigid valve drain run, cut the barbed section off the drain fitting for access to the 3/8" pipe threads. Then plumb a rigid drain as needed. An optional drain fitting, part no. 7141239, is available from EcoWater to connect a standard garden hose, or 5/8" I.D. hose onto a barb.

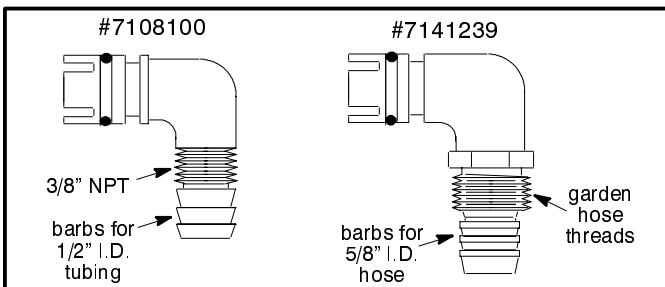

SELECT INSTALLATION LOCATION

Consider all of the following as an installation location for the Eco System Unit is selected.

- To condition all water in the home, install the Eco System Unit close to the water supply inlet, and before all other plumbing connections, EXCEPT outside water pipes. Outside faucets should remain on hard water to avoid wasting conditioned water and salt.
- A nearby drain is needed to carry away regeneration discharge water. A floor drain is preferred, with a laundry tub, sump, standpipe, etc., other options (check your local codes).
- **The Eco System Unit works on 24 volts only.** A transformer is included to reduce 120-60 Hz house electrical power. Provide an approved, grounded outlet within 10' of the unit. The Eco System Unit includes a 10' power cable for connection between the transformer and the timer.
- Position the Eco System Unit at least 6" from surrounding walls, or other appliances, to allow access for adding salt and servicing.
- Locate the Eco System Unit, in the plumbing system, AFTER all other installed water conditioning equipment, except for a taste and odor filter. A taste and odor filter is installed after all equipment. **Always install the Eco System Unit BEFORE the water heater** (see Safety Guides on page 2). To reduce the risk of hot water back-up, conditioned water piping between the Eco System Unit and water heater should be as long as possible.
- Install the Eco System Unit in a place water damage is least likely to occur if it develops a leak.
- If installing the unit in an outside location, be sure to provide protection from the elements, contamination, vandalism, and sunlight heat. The sun's heat can melt plastic parts.

1. INSTALL INLET AND OUTLET FITTINGS

NOTE: All fittings are on the small parts skin-pack.

- a. Slide the water meter turbine onto the stainless steel pin of the turbine mounting assembly...FIG. 6.
- b. Insert the turbine mounting assembly into the valve outlet port (push in firmly), up to the shoulder. Check the turbine for free movement by blowing air into the port.

NOTE: If installing the EcoWater bypass valve, see figure 6 below, or separate instructions included with it.

- c. Slide a lubricated o-ring seal onto 1 of the copper tubes. Carefully insert the copper tube into the outlet port...inset drawing, FIG. 6...and secure in place with a plastic "C" clip.

NOTE: For lubrication, use silicone grease approved for use on potable water supplies.

- d. Repeat step C on the INLET port side.

IMPORTANT: Be sure copper tubes are firmly held in place by the plastic "C" clips.

2. TURN OFF WATER SUPPLY

- a. Close the main water supply valve, near the well pump or water meter.
- b. Shut off the electric or fuel supply to the water heater.
- c. Open high and low faucets to drain all water from the house pipes.

3. INSTALLING THREE VALVE BYPASS

If installing a 3-valve bypass system, plumb as needed using FIG. 5 as a guide. When installing sweat copper, **be sure to use lead-free solder and flux**, as required by federal and state codes. Use pipe joint compound on outside pipe threads.

4. MOVE THE ECO SYSTEM UNIT INTO PLACE

Move the Eco System Unit (resin tank only if "free-standing" model) into installation position. Set it on a solid, smooth and level surface. If needed, place the unit on a section of 3/4" thick (minimum) plywood. Then, shim under the plywood to level the unit, FIG. 7.

CAUTION: DO NOT PLACE SHIMS DIRECTLY UNDER THE BRINE TANK. The weight of the tank, when full of water and salt, may cause the tank to fracture at the shim.

5. ASSEMBLE INLET AND OUTLET PLUMBING

Measure, cut, and loosely assemble pipe and fittings from the main water pipe (or from the bypass valves installed in step 3), to the inlet and outlet copper tubes, on the Eco System Unit.

BE SURE HARD WATER SUPPLY PIPE GOES TO THE UNIT INLET SIDE. Trace the water flow direction to be sure.

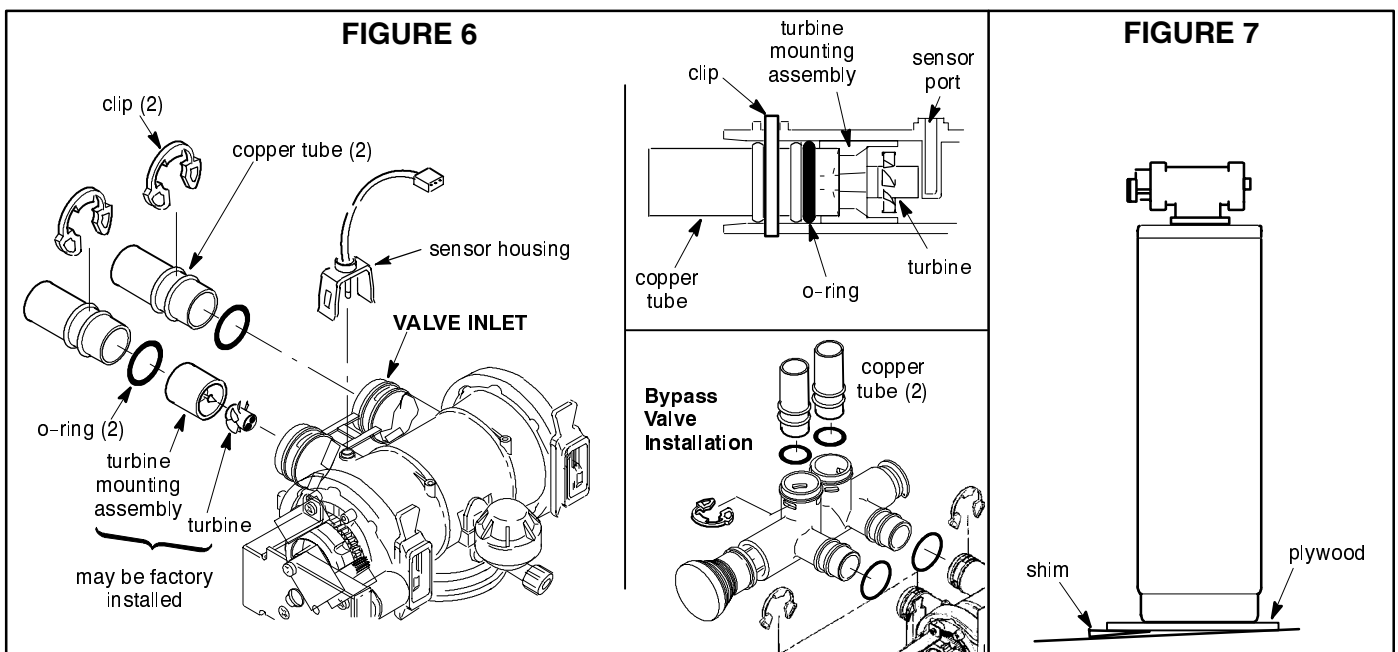

6. CONNECT INLET AND OUTLET PLUMBING

Complete the inlet and outlet plumbing as applicable below.

a. SOLDERED COPPER

- (1) Thoroughly clean and flux all joints.
- (2) Remove the inlet and outlet tubes from the valve (pull the plastic “C” clips) and the o-rings from the tubes. **DO NOT solder with tubes in the valve.** Soldering heat will damage the valve.
- NOTE: If installing ground as shown in figure 8B, place hose clamps on copper tubes (see step 7a).
- (3) Make all solder connections. Be sure to keep fittings fully together, and pipes square and straight.
- (4) **After plumbing has cooled**, repeat steps 1c and 1d, page 10.

IMPORTANT: Be sure copper tubes are firmly held in place by the plastic “C” clips.

b. THREADED PIPE

- (1) Apply pipe joint compound to all outside pipe threads.
- (2) Tighten all threaded joints.
- (3) If soldering to the inlet and outlet tubes, observe steps a above.

c. CPVC PLASTIC PIPE

- (1) Clean, prime and cement all joints, following the manufactures instructions supplied with the plastic pipe and fittings.

- (2) If soldering to the inlet and outlet tubes, observe step a above.

7. COLD WATER PIPE GROUNDING

The house cold water pipe (metal only) is often used as a ground for the house electrical system. The 3-valve bypass type of installation, shown in FIG. 5, will maintain ground continuity. If you use the plastic bypass valve at the Eco System Unit, continuity is broken. To restore the ground, do either step a or b following.

- a. Use the included “c” clamps and wire, to make a jumper across the inlet and outlet copper tubes, FIG. 8.
- b. Install a #4 copper wire across the removed section of main water pipe, securely clamping at both ends.

8. INSTALL VALVE DRAIN HOSE

NOTE: See valve grain options on page 9.

- a. Connect a length of 1/2” I.D. hose (check codes) to the valve drain elbow, on the controller, FIG. 5. Use a hose clamp to hold the hose in place. Route the hose out through the notch in the bottom cover.
- b. Run the hose to the floor drain, and as typically shown in FIG. 5, tie or wire the end to a brick or other heavy object. This will prevent “whipping” during regenerations. Be sure to provide a 1-1/2” minimum air gap, to prevent possible sewer water backup.

continued

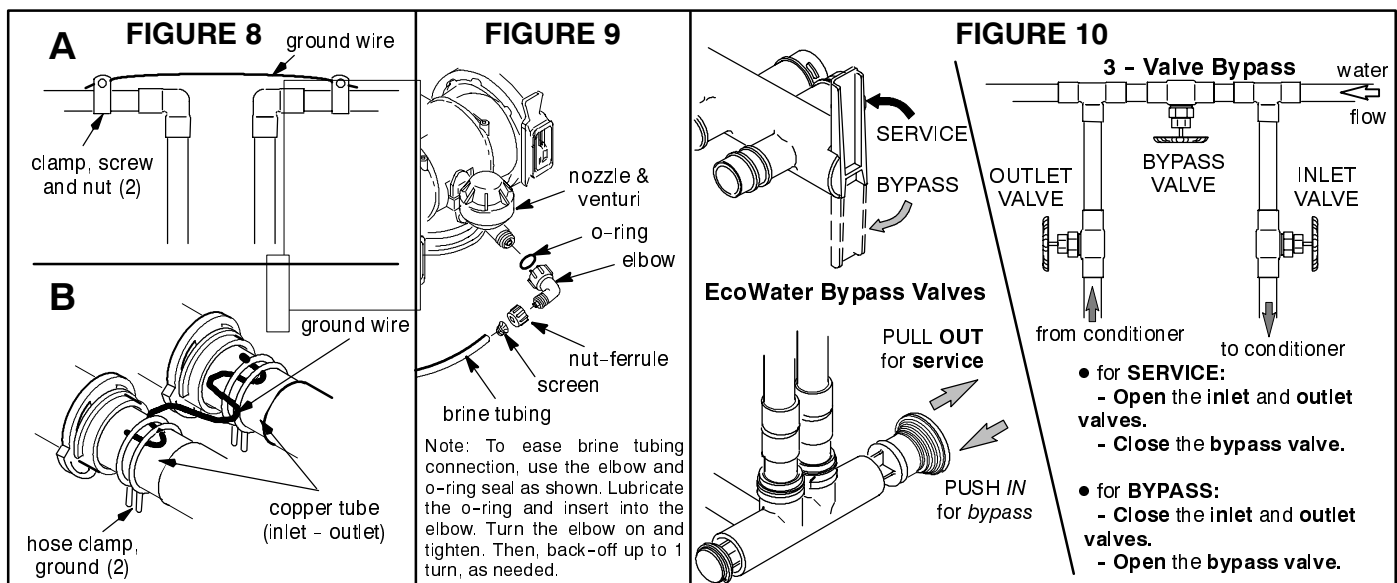



NOTE: In addition to a floor drain, you can use a laundry tub, sump, or standpipe as a good drain point for this hose. Avoid long drain hose runs, or elevating the hose more than 8' above the floor.

9. IF INSTALLING A 2-TANK, FREESTANDING MODEL, move the brine tank into position next to the resin tank. Observe the instructions in step 4, page 10.

10. INSTALL BRINE TANK OVERFLOW HOSE

a. Connect a length of 1/2" I. D. hose to the brine tank overflow elbow and secure in place with a hose clamp.

b. Run the hose to the floor drain, or other suitable drain point **no higher than the drain fitting** on the tank.

11. On 2-tank, freestanding models, connect the brine tubing to the nozzle and venturi housing, FIGS. 1, 3 and 9. Use the nut-ferrule, included on the skin-pack. Tighten the nut by hand, then another 1/4 turn with a pliers.

NOTE: Route the tubing neatly out of the way and cut it to the desired length. For longer distances, order the optional parts shown on page 29, to extend the tubing.

12. PRESSURE TESTING FOR LEAKS

To prevent excessive air pressure in the Eco System Unit and plumbing system, do the following steps EXACTLY in order.

a. Fully open 2 or more *conditioned* cold water faucets nearby the Eco System Unit.

b. Place the bypass valve(s) in "bypass" position (see figure 10).

c. Fully open the main water supply valve. Observe steady flow from the opened faucets, with no air bubbles.

d. EXACTLY as follows, place bypass valve(s) in "service".

① **SINGLE BYPASS VALVE: SLOWLY,** move the valve stem toward "service", pausing several times to allow the unit to pressurize slowly.

② **3-VALVE BYPASS:** Fully close the bypass valve and open the outlet valve. **SLOWLY,** open

the inlet valve, pausing several times to allow the unit to pressurize slowly.

e. After about 3 minutes, open a hot water faucet for about 1 minute, or until all air is expelled, then close.

f. Close all cold water faucets and check your plumbing work for leaks.

13. ADD WATER AND SALT TO THE BRINE TANK

a. Using a pail or garden hose, add about 3 gallons of water into the brine tank. **DO NOT** pour into the brinewell, FIGS. 1 and 3, page 7.

b. Fill the brine tank with salt. You can use most water conditioner salts, but it must be clean. Recommended nugget, pellet or coarse solar salts have less than 1% impurities. Salt storage capacity is shown on page 4.

NOTE: See page 23 for additional information on salt.

14. INSTALL BOTTOM CONTROLLER COVER

Referring to FIG. 11A, slide the bottom cover (spread slightly) into place, under the controller to tank clamp. Position and lock the cover tabs into the holes in...

...the rear brine tank cover, tank-in-tank models.
...the resin tank top shroud cover, freestanding models.

15. Snap the faceplate timer and top controller cover together, FIG. 11B. First, attach at the top (①). Rotate the bottom of the timer against the top cover (②).

16. CONNECT ALL LEADWIRES

a. Connect the wire harness to the valve switch, FIG. 12. The switch is on the outlet side valve cover, behind the motor.

NOTE: Check to be sure the connector is secure, on the back of the timer.

b. Fasten the sensor housing over the valve outlet port. Tabs, on the outlet port, snap into the housing to hold in place.

IMPORTANT: Be sure the small port that houses the sensor is completely dry, FIG. 6, page 10.



c. Attach the male connector, on the valve motor leadwire, to the matching female connector on the faceplate timer.

d. Connect the power cable leads to the 2 terminals on the transformer.

Caution: Be sure all wiring is away from the valve cam, which rotates during regenerations.

17. Insert the tabs, on the back of the top cover, into the bottom cover...③ in FIG. 11C. Then, rotate the top cover and timer down and lock into the bottom cover...④.

18. SANITIZING THE ECO SYSTEM UNIT

Care is taken at the factory to keep your Eco System Unit clean and sanitary. Materials used to make the unit will not infect or contaminate your water supply, and will not cause bacteria to form or grow. However, during shipping, storage, installing and operating, bacteria could get into the unit. For this reason, sanitizing as follows is suggested ☐ when installing.

...Remove the brinewell cover and pour about 1-1/2 oz. (2 to 3 tablespoons) of common household

bleach into the softener brinewell, FIGS. 1 and 3, page 7. Clorox, Linco, BoPeep, White Sail, Eagle, etc. are brand names of bleach readily available. **Replace the brinewell cover.**

...The final step in the sanitizing procedure is done as you complete the following steps, including timer programming on page 15.

☐ Recommended by the Water Quality Association. On some water supplies, the Eco System Unit may need periodic disinfecting.

19. CONNECT TO ELECTRICAL POWER

Plug the transformer into a continuously “live”, grounded, 120V-60Hz house electrical outlet, approved by local codes. **THE UNIT WORKS ON 24V ONLY. DO NOT CONNECT WITHOUT THE TRANSFORMER.**

20. Install, or close, the salt tank cover.

COMPLETE THE PROGRAMMING STEPS ON PAGES 14 AND 15,...and RESTART THE WATER HEATER, STEP 7 ON PAGE 15.

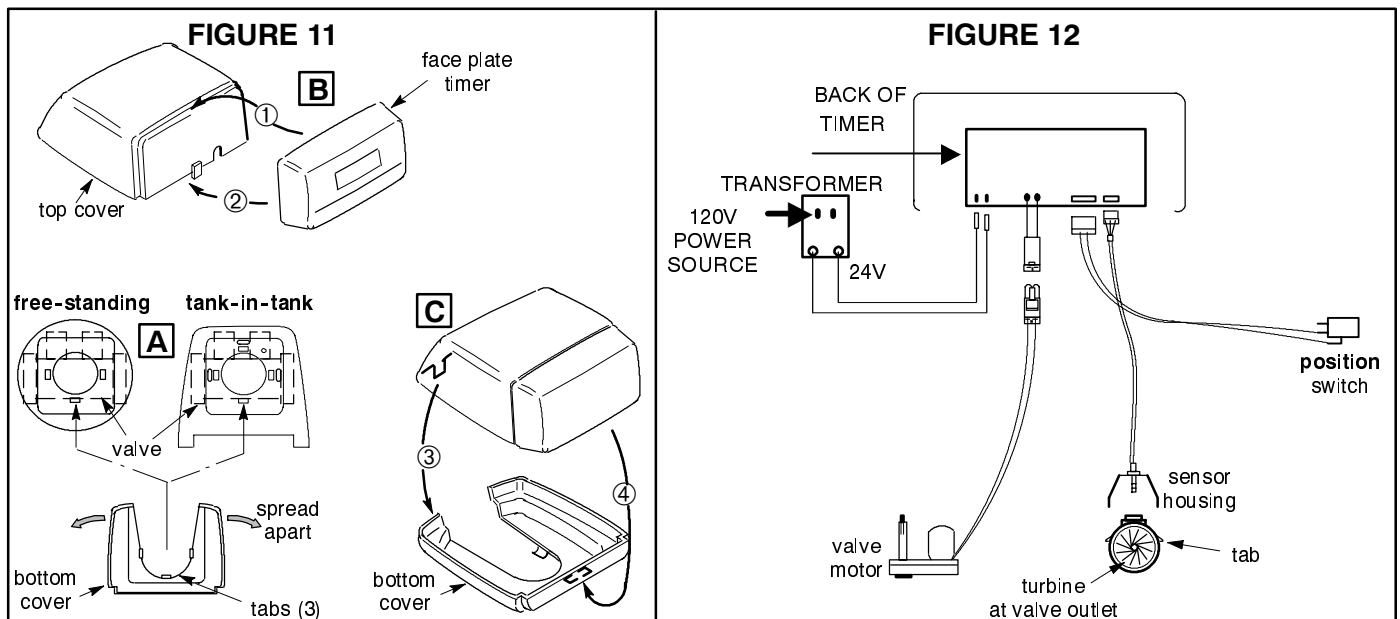

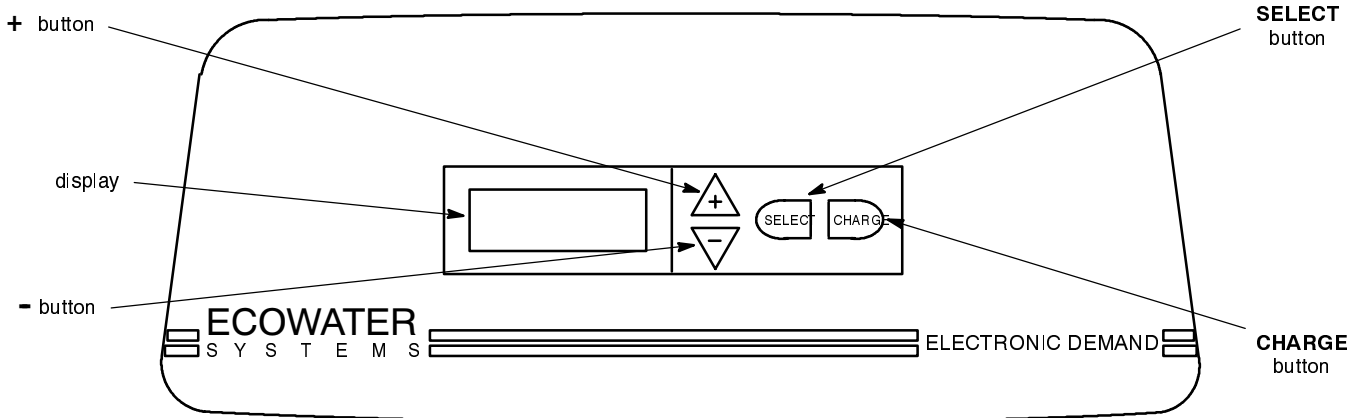

When the transformer is plugged in, a “beep” will sound, followed by the factory set model code for a few seconds. Then, a test number (example: 5.1) shows, followed by a 12:00 AM present time display.

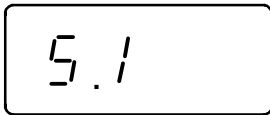

1. MODEL CODE: The timer is factory set to the R model code (see table), which provides the shortest recharge times and greatest water savings. For operation at higher efficiency levels, the HR model selection is required (see the product specification

sheet). Do the following to change to the HR code, if desired.

- Press SELECT and *hold* for 3 seconds.
- Again, press SELECT and *hold* for 3 seconds to display the factory set R code.
- Use the (Δ) button to set the HR code. if you pass by the correct HR code, use the (∇) button. **Be sure to set the correct code, or the Eco System Unit will operate on incorrect timing.**

When you are certain the correct code appears, press SELECT to set. A test number (example: 5.1) will show again for a few seconds, followed by a flashing 12:00 AM. The charge bar will show 0% until after the first regeneration (see page 15).

MODEL NUMBER (on rating decal) $\blacktriangleright \blacktriangleright$	3000 R20, 3002 R20, 3200 R20, 3000 R20 PLUS	3000 R30, 3002 R30, 3200 R30, 3000 R30 +PLUS, 3002 R30 + PLUS	3000 R40 3002 R40	3000 R70 3002 R70				
MODEL CODE $\blacktriangleright \blacktriangleright$	R20	HR20	R30	HR30	R40	HR40	R70	HR70

● **SOUND “BEEPER”**- A “beeper” sounds while pressing buttons for timer setup. One beep signals a change in the faceplate display. Repeated beeps means the timer will not accept a change from the button you have pressed, telling you to use another button. For example, while setting the hardness number, the beeper sounds repeatedly when the display reaches 1 using the (∇) button, or 125 using the (Δ) button.

2. SET THE PRESENT TIME: Again, use the (Δ) or (∇) buttons to set the present time of day, being sure AM or PM shows, as applicable. Press (Δ) to move the display ahead; press (∇) to move the time backward. NOTE: Each press of a button changes the time by 1 minute. Holding a button in changes the time by 32 minutes each second.

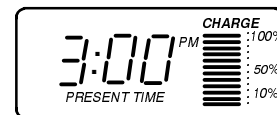

NOTE: TO RESET THE PRESENT TIME , IF FLASHING AFTER A POWER OUTAGE, DO STEP 2. Then, press SELECT 4 times to steady the display.

3. SET WATER HARDNESS: Press the SELECT button once to display a flashing 15 and HARDNESS. Set the grains per gallon hardness of your water supply (determined by water analysis, or call your local water department). Use the (▲) button to advance the number; use the (▼) button to reduce the number. Each press of a button changes the display by 1, between 1 and 25. From 25 to 125, the display changes 5 at a time. Hold a button in for fast number change. NOTE: To compensate for iron in the water, add 5 to the hardness number for each 1 ppm of iron.

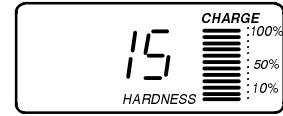

4. SET RECHARGE (REGENERATION) TIME: Press SELECT to display a flashing 2:00 AM, and RECHARGE TIME. At this setting, the Eco System Unit begins recharge, or regeneration, at 2:00 AM., ending no later than 4:30 AM. This is a good time in most households because water is not being used. (If hot water is used while the unit is regenerating, the water heater will refill with hard water.) To select a different recharge start time, use the (▲) or (▼) button.

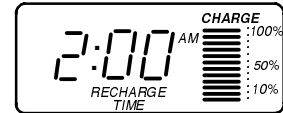

5. Press SELECT to display AVERAGE DAILY GALLONS (no adjustments), and press SELECT once more to return the present time of day.



6. Press the CHARGE button and hold for 3 seconds until RECHARGE begins to flash in the display, starting a recharge. This recharge draws the bleach (see step 18, page 13) through the Eco System Unit to sanitize it and to purge any air remaining in the resin tank assembly.



7. RESTART THE WATER HEATER: Turn on the electric or fuel supply to the water heater, and light the pilot, if applies.
NOTE: The water heater is filled with HARD water and, as hot water is used, it refills with conditioned water. In a few days, the hot water will be fully conditioned. To have fully conditioned hot water immediately, wait until the recharge (step 6) is over. Then, drain the water heater until water runs cold.

INSTALLATION OF THE ELECTRONIC DEMAND ECO SYSTEM UNIT IS COMPLETE. Additional faceplate timer features and options are described below, and on following pages.

FEATURES AND OPTIONS

CHARGE BAR DISPLAY

The charge bar is continually displayed, and shows at a glance the percentage of conditioned water capacity remaining. After a recharge, or regeneration, the charge bar returns to the 100% charge position.

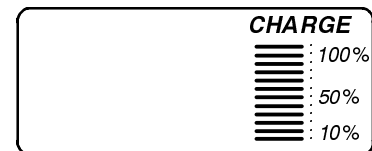

NOTE: When electrical power is applied to the timer, the charge bar is at 0% until after the initial regeneration in step 6 above.

FLASHING “RECHARGE”

While the Eco System Unit is in a recharge cycle, the word “RECHARGE” flashes in the display until the unit returns to conditioned water service.

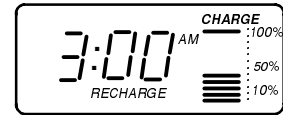

FLASHING “RECHARGE TONIGHT”

When the faceplate computer determines a recharge is needed to restore conditioned water capacity, it initiates “RECHARGE TONIGHT”. At the next programmed recharge start time, the recharge cycle will begin. Flashing RECHARGE then replaces the flashing RECHARGE TONIGHT.



INITIATING EXTRA RECHARGES

1. RECHARGE NOW: Press and *hold* the CHARGE button for 3 seconds, until RECHARGE begins to flash in the display. A recharge begins immediately.

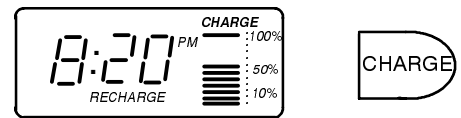

To assure an adequate supply of conditioned water, at times of unusual or *unexpected* high water use demand, use the RECHARGE NOW feature. For example, if you have guests and the charge bar is at or below 50%, you could deplete conditioned water capacity before the next recharge is automatically initiated. To be sure this will not happen, use RECHARGE NOW to restore 100% conditioned water capacity.

2. RECHARGE TONIGHT: Press and immediately release the CHARGE button. RECHARGE TONIGHT will flash in the display. When this feature is set, the Eco System Unit will regenerate at the next programmed start time. This feature is beneficial to assure a sufficient supply of conditioned water for an *expected* heavy water usage the next day.

To cancel a recharge when RECHARGE TONIGHT is flashing, press and immediately release the CHARGE button.

PROGRAM MEMORY

If electrical power to the Eco System Unit goes off, the time display is blank, but the faceplate timer keeps the correct time for at least 2 days. When electrical power comes on again, you have to reset the present time only if the display is flashing. The MODEL CODE, HARDNESS and RECHARGE TIME never need resetting unless a change is desired.

Even if the timer is incorrect, after a long power outage, the unit works as it should to keep your water conditioned. However, regenerations may occur at the wrong time of day until you reset the timer to the correct time of day. To reset present time, see step 2 on page 14.

AVERAGE DAILY GALLONS

If you want to know the average gallons of water your household uses each day, press the SELECT button 4 times to display this figure. The average daily gallons is based on your past 7 days of water usage. The figure adjusts daily at midnight. Press SELECT once more to return the present time, or it will return automatically in 4 minutes.



The following features and options are selected or observed in a SECONDARY TIMER MODE. Some of these may be beneficial to the homeowner, and others to the service technician. Some features are helpful to both homeowner and servicer. Each feature is listed in the order that these displays occur when passing through the secondary mode.

NOTE: The present time display will return if more than 4 minutes pass without a faceplate button being pressed.

TO ENTER THE SECONDARY MODE, Press SELECT and hold for 3 seconds.

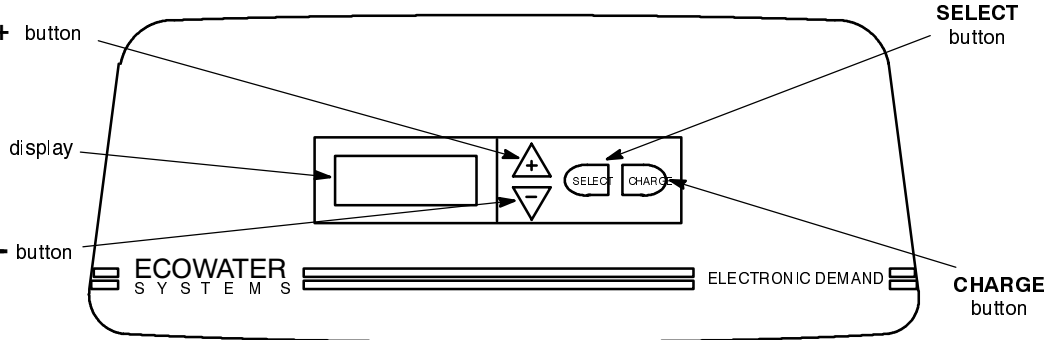

1. Gallon (or Liter) Total Count: This is a measure of all water that has passed through the Eco System Unit since installation. The display will total up to 99,999 gallons before beginning over at 0.

NOTE: When in this display, the total can be returned to 0 by pressing the (▽) button.

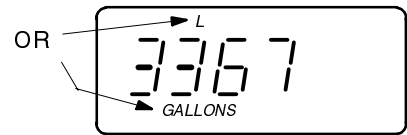

2. Flow Rate, Gallons (or Liters) Per Minute: Press SELECT once more to access this display. The display shows the flow rate, in gallons (or liters), passing through the unit. If all water using appliances and faucets are off, the display will be at 0. This display indicates positive water meter turbine operation.

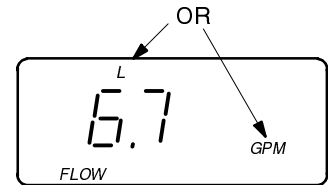

3. Operating Capacity: Press SELECT to view the current operating capacity of the Eco System Unit. The display alternates between CAP and, for example 15400. Upon installation, capacity shown is the medium operating level of the unit. After that, depending on water usage (see page 19), the actual grains capacity last recharged displays.

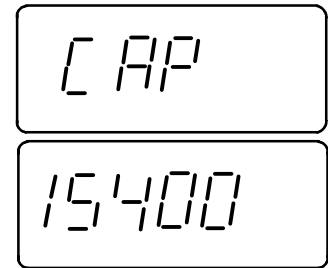

4. Valve Switches, Turbine, and Motor Diagnostic: Press SELECT again for this diagnostic display. For additional information on this display, please see page 26.

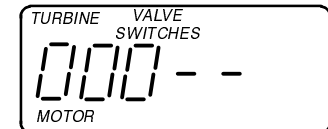

5. 12 or 24 Hour Clock: Press SELECT to display a flashing 12 hour (or 24 hour). When "12 hour" is set, the present time and recharge time displays are shown in standard clock time...1 to 12 PM, 1 to 12 AM. Military time, 0100 (1:00 AM) to 0000 (midnight), is shown when "24 hour" is set. Use the (△) or (▽) buttons to set the desired clock.

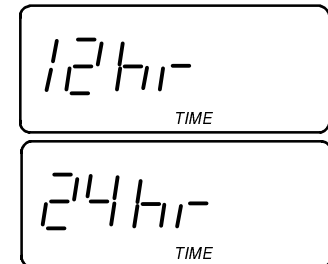

6. Gallons or Liters Measure: Press SELECT to show either GALLON or LITER flashing. If GALLON is selected, all water flow rate and usage displays are shown in gallons or gallons per minute. If LITER

is selected, the same displays are shown in liters or liters per minute. The (▲) or (▼) button is used to change this display.

7. Maximum Days Between Recharges: Press SELECT to display AUTO, or 1 day, 2 day, etc., through 15 days. The AUTO setting allows the faceplate computer to control all recharges, with intervals based on water usage. AUTO provides the most economical Eco System Unit operation. To set a maximum time (in days) between recharges, use the (▲) or (▼) button. For example, if you select 5 day in the display, the timer will assure that no more than 5 days will pass without a recharge.

NOTE: If the 24 hour clock is selected (step 5, page 17), an alternating OFF / 97 displays when SELECT is pressed again. This feature is mainly for the European market, which requires immediate recharge when 97% of the unit capacity is used. To select this feature, press the SELECT button to display ON.

8. Backwash Minutes: Press SELECT and a flashing MIN. / BACKWASH time shows in the display. The minimum time^① is either 8, 12, or 13 minutes, depending on the preprogrammed model code (see pages 14 and 27). The (▲) and (▼) buttons are used to change this time, if desired, up to a maximum of 30 minutes.

NOTE: The length of each stage (fill, brining/brine rinse, backwash, fast rinse) of the recharge cycle is automatically controlled by the faceplate computer. This time is computed based on water usage, water hardness, size of the Eco System Unit resin bed, etc. *Although the lengths of backwash and fast rinse are changeable, only a qualified technician should adjust the times.*

9. 2nd Backwash: Press SELECT again to display 2ND BACKWASH / OFF. Two backwash cycles are beneficial on some water supplies, especially if it has high sediment or iron content. When selected, a backwash and fast rinse cycle will follow the fill cycle of recharge. Then, the normal recharge sequence (brining, brine rinse, backwash, fast rinse) resumes. To select the 2nd backwash, press the (▲) button to display ON, or press the (▼) button to change from ON to OFF.

10. Rinse Minutes: Press SELECT and a flashing MIN. / RINSE time shows in the display. The minimum time is^① 2, 3, or 4 minutes, depending on the preprogrammed model code (see pages 14 and 27). The (▲) and (▼) buttons are used to change this time up to a maximum of 30 minutes.

^① The minimum time adjustment available is 1 minute.

► Press SELECT once more to return the present time display.

NOTE: ALSO SEE SERVICE INFORMATION, PAGES 24 THROUGH 27.

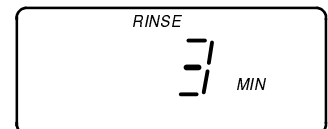
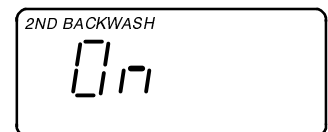
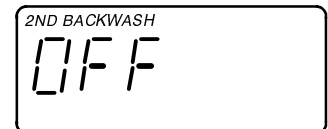
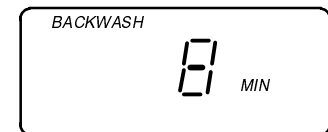
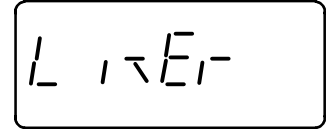
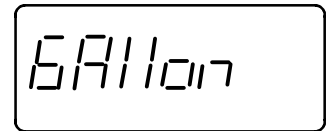

ELECTRONICS

WATER METER:

The water meter consists of a turbine, turbine mounting assembly, and sensor housing. It is located at the valve outlet port, FIG. 6, page 10. As water passes through and spins the turbine, 2 magnets (in the turbine) cause a back-and-forth movement of a switch in the sensor housing. This switch movement sends a pulse to the faceplate timer.

FACEPLATE TIMER:

The faceplate timer is actually a small computer. As it receives pulses from the water meter, it converts

them to gallons of water passing through the Eco System Unit. It multiplies this water usage information times the water hardness (preprogrammed into the timer) to continually calculate the conditioned water capacity required. The computer adjusts daily to water using habits, seeking to supply conditioned water for the longest time, using the least (and most efficient) amount of salt and water to regenerate.

When the computer determines more capacity is needed, it schedules a regeneration at the next regeneration starting time (2:00AM, or as otherwise preset). RECHARGE TONIGHT shows in the display to inform of the coming regeneration.

SERVICE, AND REGENERATION

The Eco System Unit is filled with a man-made resin material, called the *resin bed*. The resin looks somewhat like coarse sand, but the beads are round and smooth. Resin has the ability to remove hardness minerals from water by ion-exchange.

SERVICE (FIG. 14):

Hard water enters the Eco System Unit, passes through the valve and down into the resin tank and resin bed. As it passes through the bed, hardness minerals are extracted from the water and held by the resin beads. Conditioned water exits the resin tank through the bottom distributor, flows up the internal standpipe, into the valve, and out to the house pipes.

In time, the resin beads hold all the hardness minerals they can, and cleaning with a salt solution (brine) is needed. Regeneration and recharge are words used to describe this cleaning.

REGENERATION, OR RECHARGE:

The faceplate timer determines when a regeneration is needed (see above). Regeneration starts at 2:00AM, or other preselected time, and consists of 5 different steps, or cycles. These are *fill*, *brining*, *brine rinse*, *backwash*, and *fast rinse*.

STEP 1 - FILL CYCLE (FIG. 15): Salt, dissolved in water, is called brine. Brine is the cleaning agent for the resin bed. To make brine, water is needed in the brine tank salt storage area. A controlled water flow to the brine tank takes place during fill.

To enter fill, the Eco System Unit valve repositions slightly (motor energized). A valve passage opens allowing *conditioned* water to flow through the nozzle and venturi, to the brine valve, and into the brine tank. Fill cycle length is regulated by the timer, depending upon how much cleaning is needed to remove all hardness minerals, and restore 100% capacity.

continued, page 21

FIGURE 14
SERVICE CYCLE

WATER FLOW PATHS

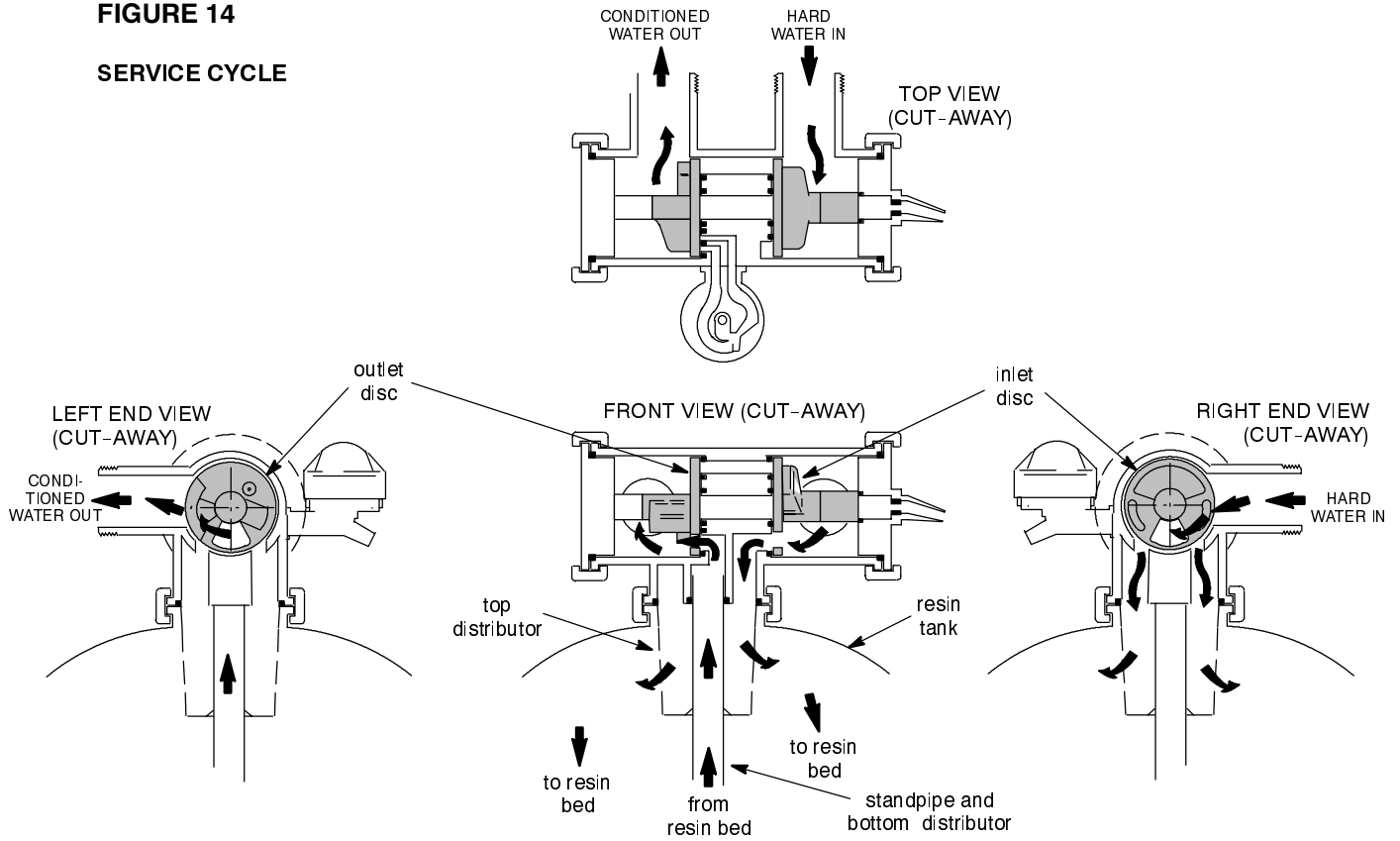
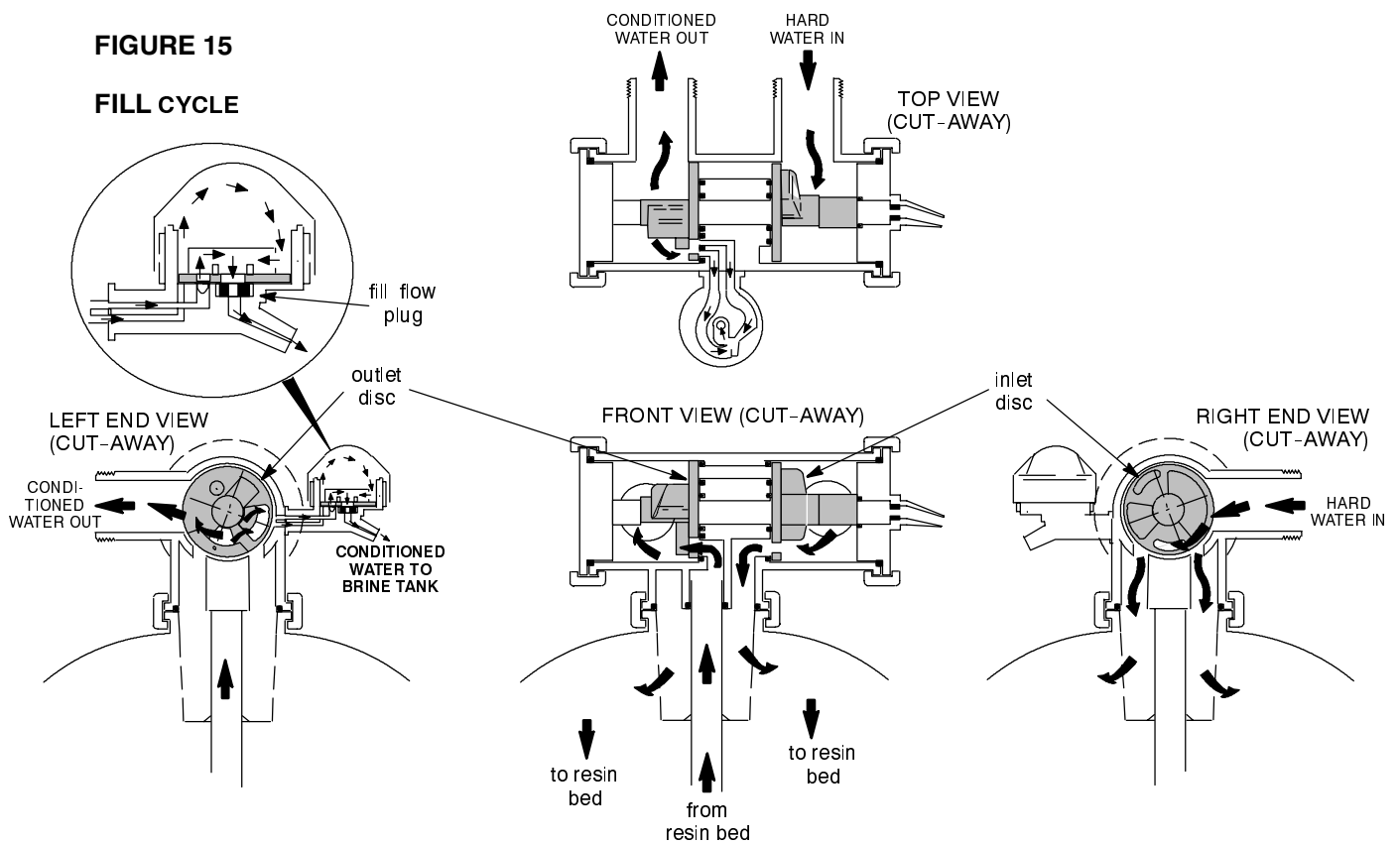

FIGURE 15
FILL CYCLE



**STEP 2 - BRINING CYCLE, and
STEP 3 - BRINE RINSE CYCLE (FIG. 16):**

The timer energized motor moves the valve out of fill and into brining. A port opens, routing water to the nozzle. Flow, through the nozzle and into the venturi, creates a suction in the brine tubing and brine valve. The suction draws brine out of the brine tank, and it mixes with water at the nozzle and venturi. Brine and water flow back into the valve, down the internal standpipe, and into the resin bed. As brine passes through the resin bed, hardness minerals are released from the resin and carried with water flow to the drain.

After all brine is drawn from the brine tank, the brine valve float seats to prevent air induction. Water continues to flow in the same direction except for the discontinued brine flow. Hardness minerals and brine rinse from the resin bed and flow to the drain.

Brining and brine rinse time is also variable and controlled by the timer (see page 27).

BYPASS HARD WATER: During brining and brine rinse (also backwash and fast rinse, page 22), *hard water* is bypassed through the valve and available at house faucets. Avoid using HOT water however, because the water heater will refill with hard water.

FIGURE 16

**BRINING and
BRINE RINSE CYCLES**

WATER FLOW PATH

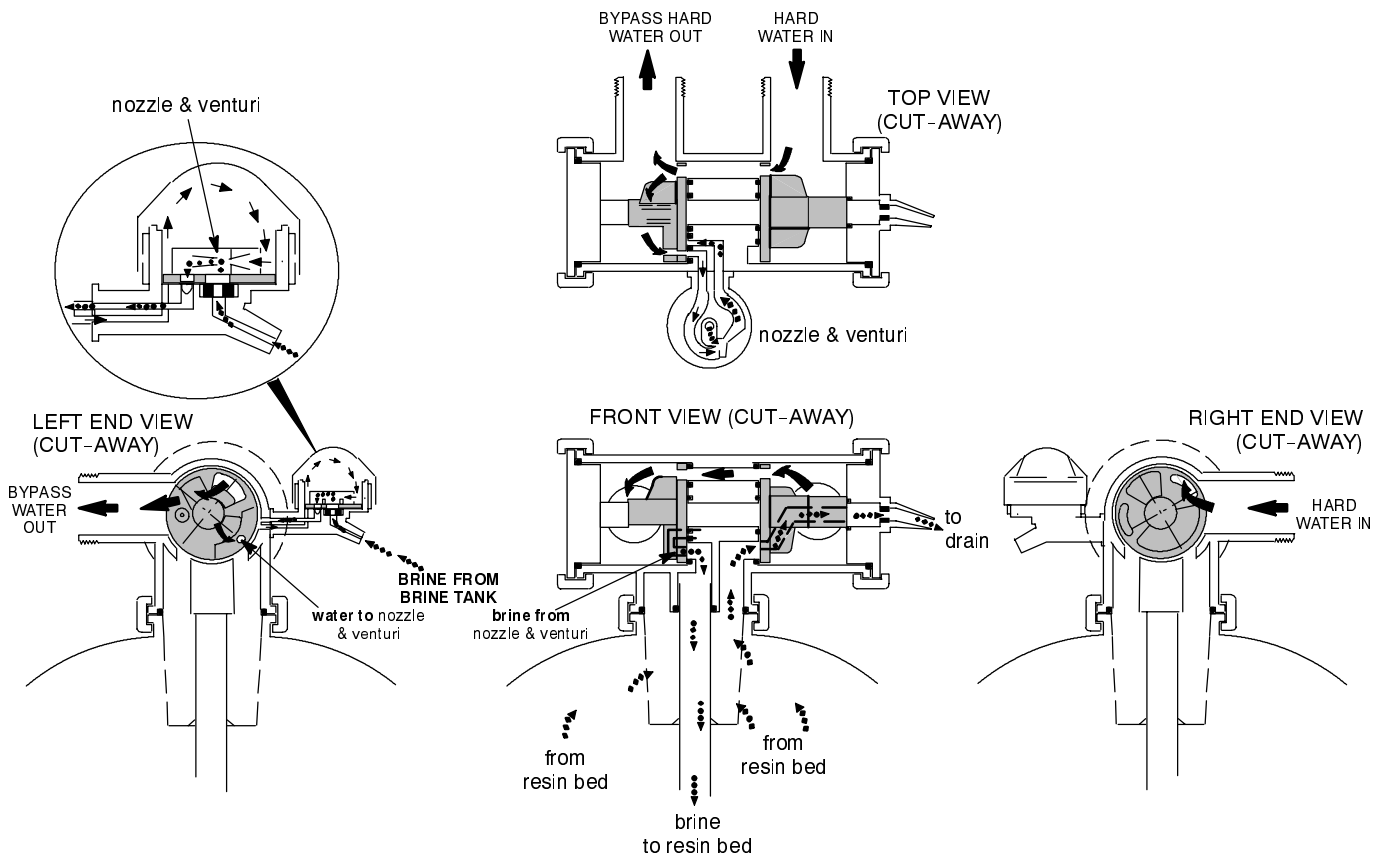

FIGURE 17

STEP 4 - BACKWASH: The motor drives the valve to end brine rinse and begin backwash. In backwash, a fast *upward* flow of water, through the resin bed, flushes remaining hardness minerals, brine, dirt, sediments, iron deposits, etc., from the bed and to the drain. The fast flow lifts and expands the resin bed for maximum cleaning.

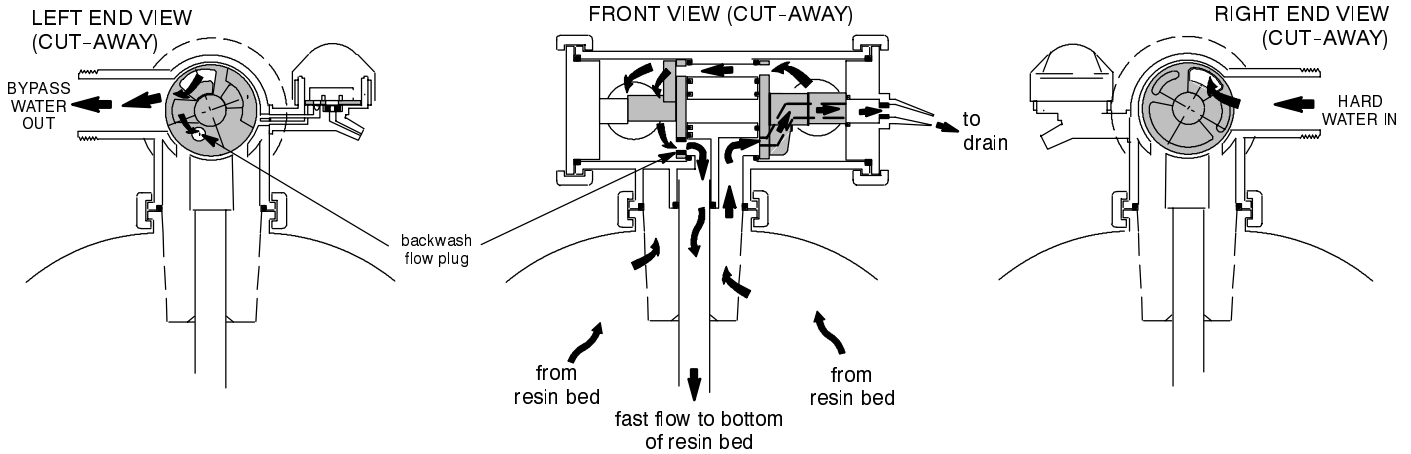
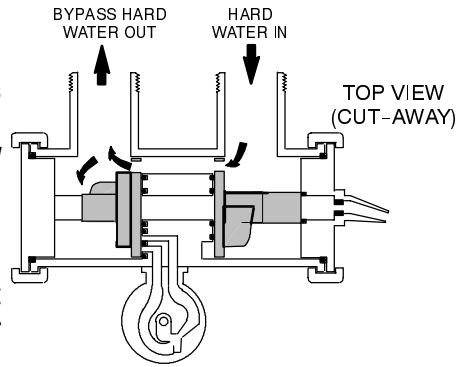
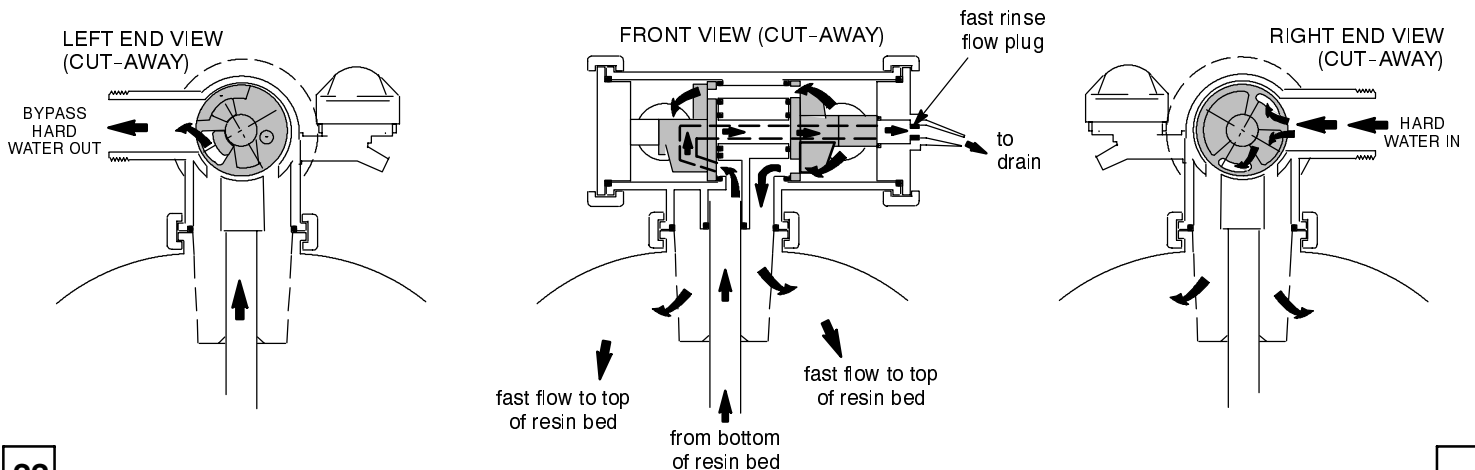
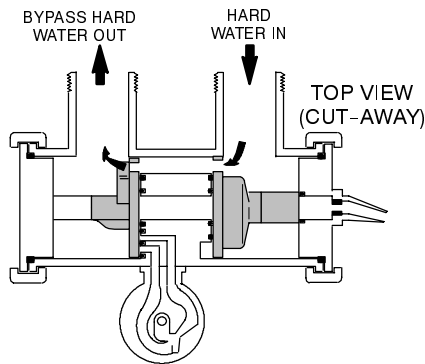

FIGURE 18

STEP 5 - FAST RINSE: After backwash, valve rotation places the valve in fast rinse. The continued fast flow of water changes direction to flow *down* through the resin bed. Any brine, hardness minerals, etc., still at the bottom of the resin bed, are flushed up the standpipe and out the valve to the drain. The resin bed is packed by the fast flow, and prepared for service. The motor is energized a final time to return the valve to service position.



REFILLING WITH SALT

Remove the brine tank cover and check the salt storage level frequently. If the Eco System Unit uses all the salt before you refill it, you will get hard water. Until you have established a refilling routine, check the salt every 2 or 3 weeks. **ALWAYS** refill if less than 1/2 full. **Be sure the brinewell cover is on.**

RECOMMENDED SALT: Nugget, pellet, button, coarse solar, etc., water conditioner salt is recommended. This type of salt is from high purity evaporated crystals, sometimes formed, or compressed, into briquets. It has less than 1% insoluble (will not dissolve in water) impurities. *Clean, high grade* rock salts are acceptable, but may require frequent brine tank cleaning to remove the “sludge” residue (insolubles).

SALT NOT RECOMMENDED: Rock salt, high in impurities, block, granulated, table, ice melting, ice cream making salts, etc., are not recommended.

SALT WITH IRON REMOVING ADDITIVES: Some salts have an additive to help a water conditioner handle iron in a water supply. Although this additive may help keep the resin bed clean, it may also release corrosive fumes that will weaken and shorten the life of some Eco System Unit parts.

BREAKING A SALT BRIDGE

Sometimes, a hard crust or salt bridge forms in the brine tank. It is usually caused by high humidity or the wrong kind of salt. When the salt bridges, an empty space forms between the water and the salt. Then, salt will not dissolve in the water to make brine. Without brine, the resin bed does not regenerate and you will have hard water.

If the storage tank is full of salt, it is hard to tell if you have a salt bridge. Salt is loose on top, but the bridge is under it. Take a broom handle, or like tool, and push it straight down into the salt. If a hard object is felt, it's most likely a salt bridge. *Carefully* push into the bridge in several places to break it.

NOTE: *In humid areas, it is best to keep the salt storage level lower, and to refill more often.*

CLEANING THE NOZZLE AND VENTURI

A clean nozzle and venturi (FIG. 19) is a must for the Eco System Unit to work right. This small unit creates the suction to move brine from the brine tank, into the resin tank. If it should become plugged with sand, silt, dirt, etc., the Eco System Unit will not work, and you will get hard water.

To get to the nozzle and venturi, remove the Eco System Unit top cover. **Be sure the unit is in service cycle** (no water pressure at nozzle and venturi). Then, holding the nozzle and venturi housing with 1 hand, turn off the cap. *Do not lose the o-ring seal.* Lift out the screen support and screen. Then, remove the nozzle and venturi. Wash the parts in warm, soapy water and rinse in fresh water. If needed, use a small brush to remove iron or dirt. Be careful not to scratch, misshape, etc., surfaces of the nozzle and venturi. Also, check and clean the gasket and flow plug(s) if dirty.

Carefully replace all parts in the correct order. Lubricate the o-ring seal with silicone grease and locate in position. Install and tighten the cap, **by hand only.** **Do not overtighten** and break the cap or housing.

FIGURE 19

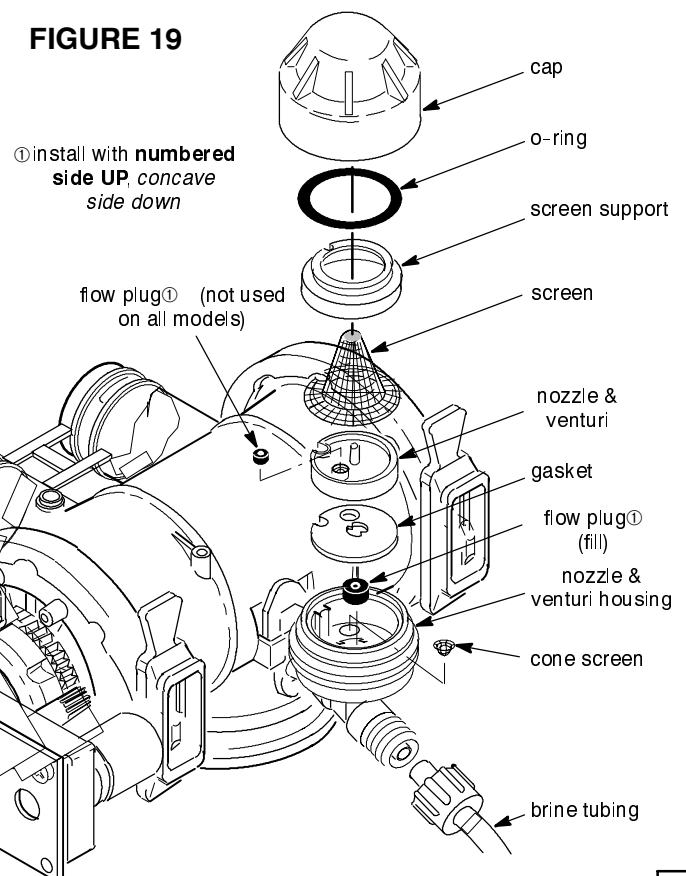

RESIN BED CLEANING

If the water supply contains “clear water” iron (see page 5), regular resin bed cleaning is needed to keep the bed from coating with iron. Use resin bed cleaner, available from EcoWater, following directions on the container. Clean the resin every 6 months, or more often if iron appears in your conditioned water supply.

ADDING RESIN

Normally, the resin bed (FIG. 20) will last the lifetime of the Eco System Unit. However, certain conditions may require partial or total replacement of the resin bed. Some of these conditions are:

- (1) damaged top and/or bottom distributors have allowed resin to escape
- (2) resin bed iron fouled beyond use
- (3) some water supplies cause resin degradation

To add more resin, or to replace the entire bed, use the following guides. See resin and gravel requirements on page 27.

MODEL NUMBER	RESIN TANK SIZE	FREE-BOARD RANGE*	LBS. RESIN PER INCH BED DEPTH* [□]
3000, 3002, 3200-R20	8 x 35	8.5 - 12.5	1.6
3000-R20 +PLUS 3000, 3002, 3200-R30,	10 x 35	10.5 - 14.5	2.2
3000 and 3002-R30 +PLUS 3000, 3002-R40,	10 x 47	14.5 - 18.5	2.2
3000, 3002-R70	12 x 54	20 - 24	3.4

* See page 25 □ does not include carbon in +plus models

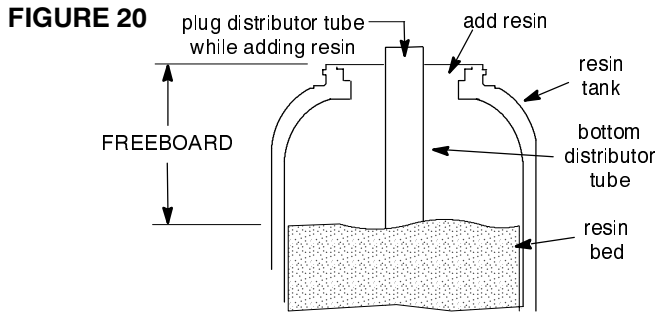

IMPORTANT NOTES:

Turn off the water supply and relieve pressure...see below.

Handle the resin tank carefully. It is heavy when filled with resin and water.

Do not lose o-ring seals or other small parts.

Refer to the assembly instructions, page 7, and to installation steps 1, 12, 16, and 18 through 20 to reassemble and restart the unit.

CAUTION: ALWAYS relieve water pressure in the EcoSystem Unit, as follows, before removing parts from the valve or resin tank.

DE-PRESSURIZE

1. Put bypass valve(s) in bypass position.
2. Do Manual Advance step 1, page 27, (fill water to brine tank will depressurize the resin tank).

PRESSURIZE

1. Put bypass valve(s) in service position.
2. Do Manual Advance steps 2-5, page 27, to return unit to service.

ALTERNATE METHOD

3-VALVE BYPASS

DE-PRESSURIZE

1. Close the INLET valve.
2. Open HOT and COLD conditioned water house faucets.
3. Close the OUTLET valve and open the BYPASS valve.
4. Close all house faucets.

PRESSURIZE

1. Open HOT and COLD house faucets.
2. Close the BYPASS valve and open the OUTLET valve.
3. **Slowly**, open the INLET valve.
4. Close all house faucets

ECOWATER BYPASS VALVE

DE-PRESSURIZE

1. Close the house main water supply valve.
2. Open HOT and COLD conditioned water faucets.
3. Push or rotate the bypass valve handle to bypass position.

Note: For hard water bypass to house faucets, reopen the main water supply valve.

PRESSURIZE

1. Open HOT and COLD house faucets (main water supply valve open).
2. Pull or rotate the bypass valve handle to service position.
3. Close all house faucets.

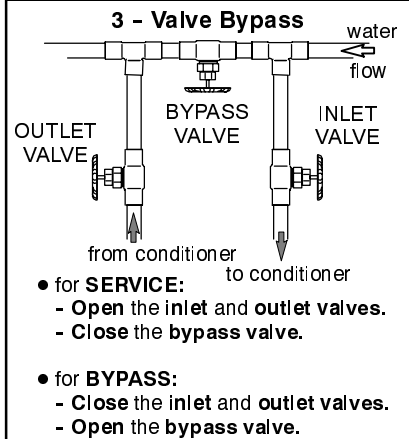
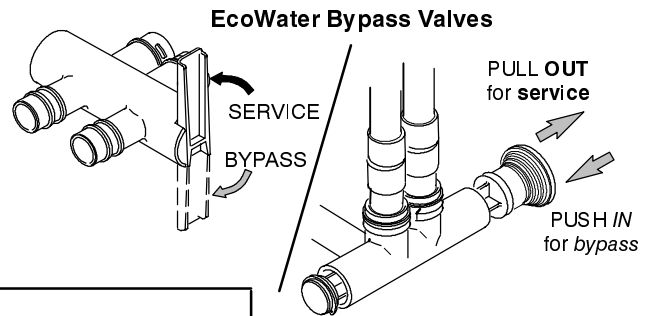

*Freeboard range and lbs. of resin per inch bed depth, in the preceding chart, are provided only as a guide for maintenance when adding to, or if replacing the entire bed with new, fully regenerated, resin with typical moisture content. Freeboard can vary several inches depending on resin bed conditions including...if regenerated or exhausted, total moisture content, settling during shipping and storage,

tolerance variables in resin tank size, and amount and type of gravel underbedding.

Each model is factory loaded with the specific pounds or cubic feet of resin required, not by a freeboard measurement. Refer to page 27 for this information.

ECO SYSTEM UNIT OPERATION, ELECTRONIC CHECKOUT

ALWAYS MAKE THE INITIAL CHECKS FIRST

INITIAL CHECKS:

1. Does the time display show the correct time of day?
...If display is blank, check power source to the Eco System Unit.
...If time is flashing, power was off for over 2 days. The unit resumes normal operation, when power returns, but regenerations occur at the wrong time.
...If an error code shows in the display (example: Err03), go to AUTOMATIC ELECTRONIC DIAGNOSTICS, below.
2. Plumbing bypass valve(s) must be in **service** position (all the way open or closed, as applies).
3. Inlet and outlet pipes must connect to the Eco System Unit inlet and outlet respectively.
4. Is the transformer plugged into a "live", grounded wall outlet, and the power cable fastened securely?

5. The valve drain hose must be free of kinks and sharp bends, and not elevated over 8' above the floor.
6. Is there salt in the brine tank?
7. Is the brine tubing connected? See FIG. 9, page 11.
8. Press the SELECT button 2 times to display the hardness setting. Be sure it is the correct setting for the household's water supply. -- Make a hardness test of the raw water and compare with the hardness setting. Also test a conditioned water sample to verify if a problem exists. --Press SELECT twice more to return the present time display.

If you do not find a problem after making the initial checks, do MANUAL INITIATED ELECTRONIC DIAGNOSTICS, and the MANUAL ADVANCE REGENERATION CHECK, pages 26 and 27.

E.A.S.E.: EcoWater demand timers have the latest diagnostic technology. With E.A.S.E., or Electronic Automated Service Evaluation, a service person or homeowner can transmit operational data through the telephone, to a personal computer (PC). The PC processes the data to determine if all electrical functions are working normally, or helps to identify a problem should one occur. Ask your participating EcoWater dealer for more information on this feature.

AUTOMATIC ELECTRONIC DIAGNOSTICS

The faceplate computer has a self-diagnostic function for the electrical system (except input power and water meter). The computer monitors electronic components and circuits for correct operation. If a malfunction occurs, an error code appears in the faceplate display.

appear, and the possible defects for each code.

While an error code appears in the display, all faceplate buttons are inoperable except the SELECT button. SELECT remains operational so the service person can make the MANUAL INITIATED ELECTRONIC DIAGNOSTICS, page 26, to further isolate the defect, and check the water meter.

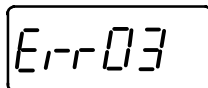

The chart below shows the error codes that could

POSSIBLE DEFECT

CODE	MOST LIKELY \blacktriangleright ----- \blacktriangleleft LEAST LIKELY
Err 01 Err 02 Err 03 Err 04	motor inoperative / wiring harness or connection to position switch / switch / valve defect causing high torque
Err 05	faceplate

PROCEDURE FOR REMOVING ERROR CODE FROM FACEPLATE: 1. Unplug transformer---- 2. Correct defect---- 3. Plug in transformer---- 4. Wait for 6 minutes. The error code will return if the defect was not corrected.

**TROUBLESHOOTING,
MANUAL INITIATED ELECTRONIC DIAGNOSTICS**

1. To enter diagnostics, press the SELECT button and *hold* for 3 seconds to display the gallons or liters of water used since installation.

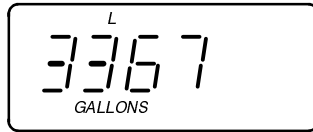

2. Continue to press SELECT until the following display shows.

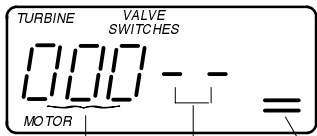

WATER METER - see **A**
 SWITCHES - see **B**
 VALVE CYCLE POSITION indicator bars - see **C**

A. The first 3 digits indicate water meter operation as follows.

000 (steady) = conditioned water not in use...no flow through the meter.

-open a nearby CONDITIONED WATER faucet-
000 to 151 (continual) = repeats display for each gallon of water passing through the meter.

If you don't get a reading in the display, with a faucet open, pull the sensor housing from the valve outlet port. Pass a small magnet back and forth in front of the sensor. You should get a reading. If you **do get a reading**, disconnect the outlet plumbing and check the turbine for binding. If you **don't get a reading**, the sensor is probably defective.

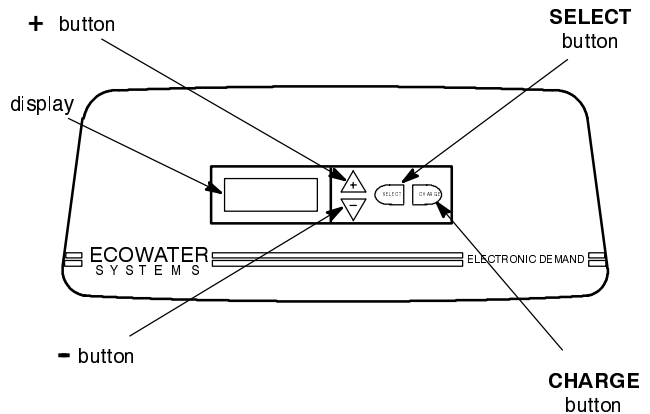
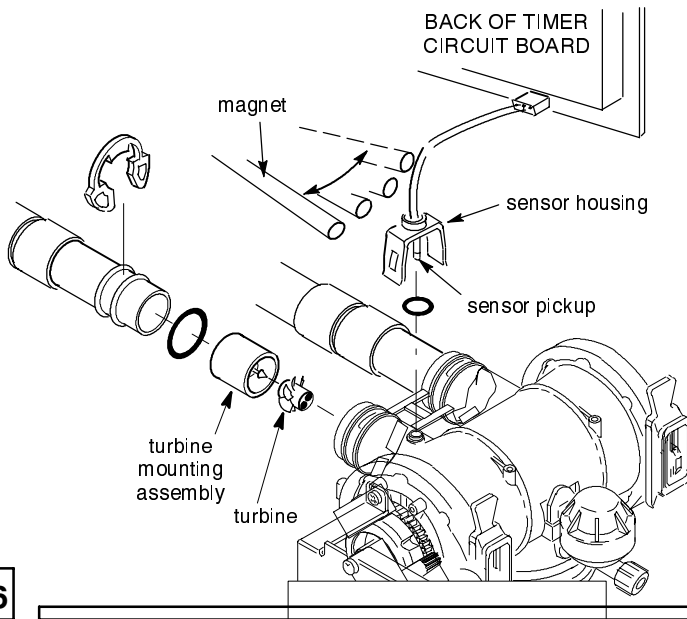

Use the recharge button to manually advance the valve into each cycle and check correct switch operation (step **B**), and observe the valve position indicator bars (step **C**).

B. The letter (P) and dash or dashes indicate position switch operation. The letter shows if the switch is closed. A dash shows when the switch is open.

NOTE: *The position switch is closed when the plunger is depressed, open when extended.*

CORRECT SWITCH DISPLAYS	VALVE CYCLE STATUS
- -	valve in service, fill, brining, backwash or fast rinse position
- P	valve rotating from one position to another

C. When advancing the valve through the recharge cycles, the charge bar indicates valve positioning as follows.

INDICATOR BARS	VALVE CYCLE POSITION
bar(s) flashing	valve moving , 1 position to another
no bars	service
1 bar	fill
2 bars	brining and brine rinse
3 bars	backwash
4 bars	fast rinse

D. While in this diagnostic screen, the following information is available and may be beneficial. This information is retained by the computer from the first time electrical power is applied to the faceplate.

...Press (▲) to display the number of days this faceplate has had electrical power applied.

...Press (▼) to show the number of regenerations initiated by this faceplate since power was first applied. (NOTE: Resets to 0 if model code is changed).

E. Press SELECT several times until the present time display returns.

**TROUBLESHOOTING,
MANUAL ADVANCE REGENERATION CHECK**

This check verifies proper operation of the gearmotor, brine tank fill, brine draw, regeneration flow rates, and other controller functions. *Always make the initial checks, and the manual initiated diagnostics first.*

NOTE: A steady time (not flashing) must show in the display.

1. Press the CHARGE button and hold for 3 seconds. RECHARGE begins to flash as the Eco System Unit enters the fill cycle of regeneration. Remove the brinewell cover and, using a flashlight, observe fill water entering the tank.

a. If water does not enter the tank, look for an obstructed nozzle and venturi, fill flow plug or brine tubing FIG. 19, page 23.

2. After verifying fill, press CHARGE to move the valve into brining*. A slow flow of water to the drain will begin. Verify brine draw from the brine tank by shining the flashlight into the brinewell and observing a noticeable drop in the liquid level.

*If the 2ND BACKWASH option is set, the valve will enter backwash and fast rinse before brining...see page 18.

NOTE: Be sure water is in contact with the salt, and not separated by a salt bridge...see page 23.

a. If the unit does not draw brine, check for...
...dirty or defective nozzle and venturi, page 23
...nozzle and venturi not seated on the gasket, or gasket defective

...restriction in valve drain, causing a back-pressure (bends, kinks, elevated too high, etc.), installation step 8

...obstruction in brine valve or brine tubing, page 7 and FIG. 9, page 11

...inner valve failure (obstructed outlet disc, wave washer defective, etc.)

3. Again press CHARGE to move the valve into backwash. Look for a fast flow of water from the drain hose.

a. If flow is slow, check for a plugged top distributor, backwash flow plug or drain hose.

4. Press CHARGE to move the valve to fast rinse position. Again look for a fast drain flow. Allow the unit to rinse for several minutes to flush out any brine that may remain from the brining cycle test.

5. To return the valve to service position, press CHARGE ONCE AGAIN.

SEE "OTHER SERVICE" ON BACK COVER PAGE.

MISCELLANEOUS SERVICE INFORMATION									
MODEL CODE	20		30		40		70		
	R	HR	R	HR	R	HR	R	HR	
LBS / CU FT RESIN ⑥	33	.63	49	.92	61	1.15	106	2	
LBS GRAVEL	8		10		10		12		
FILL CYCLE ① TIME	2 - 6		3 - 10		4 - 12		7 - 21		
	② FLOW		.3		.3		.3		
BRINE CYCLE ① TIME	37	90	41	69	54	102	58	98	
	↑	↑	↑	↑	↑	↑	↑	↑	
	③ 58	103	63	108	91	141	92	152	
	④ FLOW		.11		.15		.15		.23
BRINE R. CY. ④ FLOW	.07		.10		.10		.14		
BACK W. CY. ⑤ TIME	8		8		12		13		
	④ FLOW		1.0		1.8		4.0		
FAST RNS. CY. ⑤ TIME	2		2		3		4		
	④ FLOW		2.4		3.0		4.0		

- ① minutes, varies with capacity operating level
- ② gallon per minute flow to brine tank
- ③ includes brine rinse cycle minutes
- ④ gallon per minute flow to drain
- ⑤ factory set default minutes
- ⑥ synthetic high capacity resin – For field replacement, use the following pounds of **standard** / fine mesh resins:
R20 - 31 / 2 R40 - 57 / 4
R30 - 46 / 3 R70 - 100 / 6
- ⑦ R20 Plus models have 33.7 lbs resin, 9.6 lbs of carbon and 10 lbs gravel.
- ⑧ R30 Plus models also have 12 lbs of carbon

ECO SYSTEM UNIT ASSEMBLY

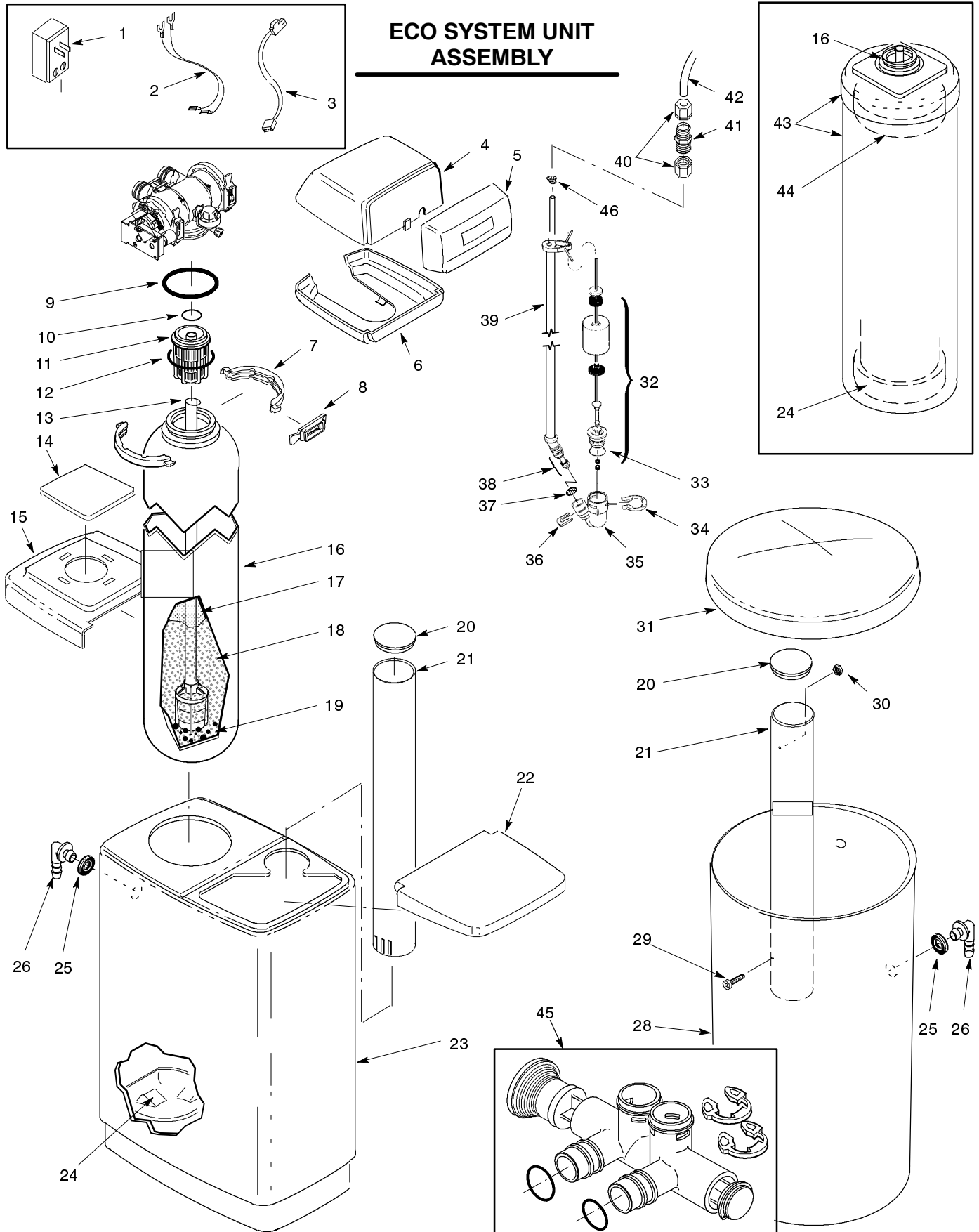

KEY NO.	PART NUMBER	PART DESCRIPTION
1	7095373	Transformer, 24V-10VA
2	7132840	Power Cable
3	7130767	Wire Harness
4	7096468	Controller Top Cover
5	7157387	Faceplate-Timer Assembly ¹
6	7096476	Controller Base Cover
7	7176292	Clamp Section, 2 req.
8	7088033	Clamp Retainer, 2 req.
9	7170296	O-ring Seal, 2-7/8" x 3-1/4"
10	7170254	O-ring, 13/16" x 1-1/16"
11	7077870	Top Distributor
12	7170270	O-ring, 2-3/4" x 3"
13	7105047	Repl. Distributor (bottom)
14	7096921	Cover (not used on tank-in-tank models)
15	7149067	Rear Cover (brine tank)
16	7114787	Resin Tank, 8" dia. x 35" (R20)
	7113066	Resin Tank, 10" dia. x 35" (R20 Plus, R30)
	7092202	Resin Tank, 10" dia. x 47" (R30 Plus, R40)
	7113074	Resin Tank, 12" dia. x 54" (R70)
17	7052202	Resin, 1 cu ft (fine mesh)
18	0502272	Resin, 1 cu ft (stand. mesh)
	0501741	Resin, 1/2 cu ft (stand. mesh)
19	7025027	Gravel (order amount needed)
20	0500283	Brinewell Cover
21	7100819	Brinewell
22	7096264	Salt Hole Cover
23	7114795	Brine Tank (rectangular)
24	7141205	Tank Base ¹
25	9003500	Grommet
26	1103200	Hose Adaptor

KEY NO.	PART NUMBER	PART DESCRIPTION
27	②	Hose Clamp (not shown)
28	7114800	Brine Tank (round)
29	②	Screw, #6-32
30	②	Nut, #6-32
31	7101611	Brine Tank Cover
32	7113008	Float, Stem and Guide Assem.
33	7170288	O-ring, 15/16" x 1-3/16"
34	1205500	Clip
35	7092252	Brine Valve Body
36	7080653	Clip
37	7131365	Screen
38	7113016	Tubing Assembly, BV
39	7195470	Brine Tube
40	9003201	Nut-Ferrule, 2 req. ^③
41	7094987	Union Connector ^③
42	7161807	Tubing, 5/16" x 20 ft
	7161768	Tubing, 5/16" x 100 ft
43	7114818	Shroud Kit
	7096913	Top Cover (only)
44	7096955	Tank Top Support (R20)
	7096963	Tank Top Support (R20 Plus, R30, R30 Plus, R40)
45	7195408	Bypass Valve (includes following)
	7172882	Stem
	7173016	O-ring, 1.11" x 1.387", 4 req.
	7175238	C-ring
	7089306	Clip, 2 req.
	7170262	O-ring, 1-1/8" x 1-3/8", 2 req.
46	7171349	Screen
■	7116488	Brine Valve Assem. (incl. key nos. 32 through 39)
■	7108118	Hose, 1/2" I.D. Drain (order length needed)

¹ This replacement faceplate-timer will replace all faceplates used on models with an AC or DC drive motor. The included special adaptor cable, #7157395 is required to adapt to AC motor versions. **Do not use faceplates, with a software version test number of 5.0 and under, on models with the DC drive motor.**

- ① part numbers for plastic spacer under tank:
R20 - #7119981 R30 - #7119999
- ② standard hardware items, purchase locally
- ③ optional parts, not included with conditioner

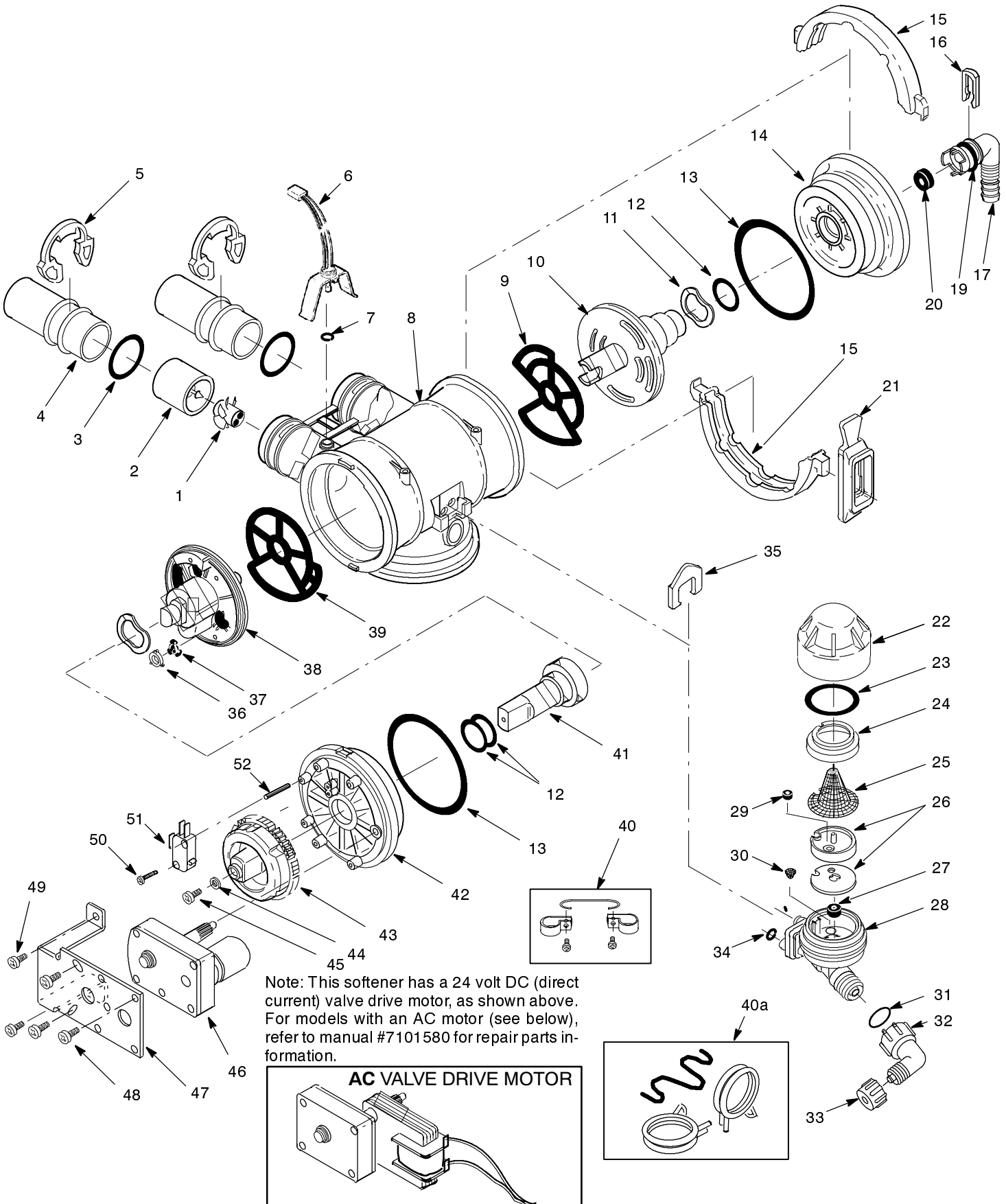

Note: This softener has a 24 volt DC (direct current) valve drive motor, as shown above. For models with an AC motor (see below), refer to manual #7101580 for repair parts information.

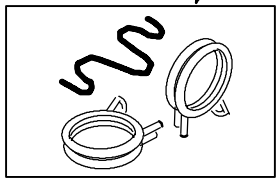
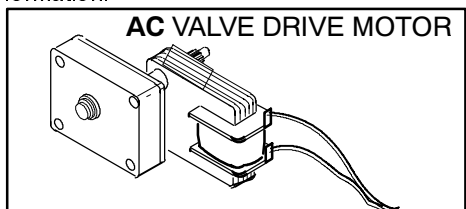

KEY NO.	PART NUMBER	PART DESCRIPTION
1	7101548	Turbine Assem. (R20, R20 <i>Plus</i> , R30)
	7123061	Turbine Assem. (R30 <i>Plus</i> , R40, R70)
2	7094898	Turb. Mount. Assy. (R20, R20 <i>Plus</i> , R30)
	7119177	Turb. Mount. Assy. (R30 <i>Plus</i> , R40, R70)
3	7170262	O-ring, 1.109" x 1.387", 2 req.
4	7077642	Copper Tube, 2 req.
	7104546	PVC Nipple (optional - not incl.)
5	7089306	Clip Retainer, 2 req.
6	7235363	Sensor Housing
7	9000803	O-ring, 3/8" x 1/2" ①
8	7159949	Disc Valve Housing
9	7078282	Inlet End Seal ②
10	7078591	Inlet Disc ②
11	7058216	Wave Washer, 2 req.
12	7170220	O-ring, 3/4" x 15/16", 3 req. ②
13	7170296	O-ring, 2-7/8" x 3-1/4", 2 req.
14	7077498	Inlet End Cap
15	7176292	Clamp Section, 4 req. ③
16	7142942	Clip
17	7108100	Drain Nipple
18	7141239	Drain Hose Adaptor (optional - not incl.)
19	7170327	O-ring, 5/8" x 13/16"
20	1110600	Flow Washer, 2.5 F.Rns. (R20)
	7097969	Flow Washer, 3.0 F. Rns. (R20 <i>Plus</i> , R30, R30 <i>Plus</i> and R40)
	7097977	Flow Washer, 4.0 F.Rns. (R70)
21	7088033	Clamp Retainer, 4 req. ③
22	7081188	Cap
23	7170262	O-ring, 1-1/8" x 1-3/8"
24	7167659	Screen Support
25	7146043	Screen
26	7113024	Nozz., Vent. (wht.) - Gasket Kit (R20 ④)
	7113032	Nozz., Vent. (blk.) - Gasket Kit (R20 ④, R20 <i>Plus</i> , R30, R30 <i>Plus</i> and R40)
	7114533	Nozz., Vent. (blu.) - Gasket Kit (R70)
27	1148800	Fill Flow Plug, .3

KEY NO.	PART NUMBER	PART DESCRIPTION
28	7085221	Noz., Ven. Assy. (R20 ④) ⑤ ⑦
	7091866	Nozz., Vent. Assem. (R20 <i>Plus</i> , R30, R30 <i>Plus</i> and R40) ⑤
	7085247	Nozz., Vent. Assem. R70) ⑤
29	0521829	Flow Plug, .1 (R20 ④)
30	7095030	Cone Screen
31	7003847	O-ring, 1/4" x 1/2"
32	7120526	Elbow, 90°
33	1202600	Nut-Ferrule
34	7170319	O-ring, 1/4" x 3/8", 2 req.
35	7081201	Clip, Nozzle & Venturi
36	7078313	Retainer
37	7104774	Flow Washer, 1.0 Bkw. (R20)
	7104570	Flow Washer, 1.7 Bkw. (R20 <i>Plus</i> , R30, R30 <i>Plus</i> and R40) - not used on R70
38	7078583	Outlet Disc ② ⑥
39	7078274	Outlet End Seal ②
40	7114826	Ground Clamp Kit
40a	7161734	Ground Wire
40a	7163427	Clamp, 2 req.
41	7091329	Driver, Outlet Disc
42	7159965	Outlet End Cap
43	7147730	Cam and Gear
44	9005900	Washer, #6
45	9006012	Screw, #8-18 x 9/16"
	7203104	Washerhead Screw, #8-18 x 1/2" (replaces key 44 and screw above)
46	7147049	Motor ⑧
47	7147057	Motor Bracket
48	7149928	Screw, #10-32 x 1/2", 4 req.
	0811297	Lockwasher, #10, 4 req.
49	7103972	Screw, #8-18 x 7/16", 2 req.
50	7140738	Screw, #4-24 x 3/4"
51	7145186	Switch
52	7140746	Expansion Pin

① optional - not required

② included in Disc Kit, #7116721

③ not all parts are shown

④ Use black nozzle along with key no. 29 flow plug on water pressures of 50 psi and less (ref: Service Bulletin #94068).

⑤ includes key nos. 22 - 27

⑥ order key nos. 36 and 37 if needed

⑦ includes key no. 30

⑧ **DO NOT** use the DC motor with faceplate-timers having a software version of 5.0 and under. Refer to manual #7101580 for correct parts to use.



CHECKING THE MODEL CODE ENTRY (see page 14)

Unplug the transformer at the electrical outlet, and plug in again. A “beep” will sound, then the model code displays for a few seconds. The software test number will then display for a few seconds, followed by the present time.

CHANGING THE MODEL CODE

IMPORTANT: Read step 1 on page 14 before changing this code.

1. Enter the secondary mode...press SELECT and *hold* for 3 seconds.
2. Press SELECT and *hold* for 3 seconds. The current model code setting shows.
3. Use the (Δ) or (∇) button until the desired model code shows.
4. Press SELECT to set.
5. Reset the timer (page 14) and reselect other desired options.

continued from page 27

OTHER SERVICE

HARD WATER BYPASS (hard water “bleeds” into conditioned water supply).

1. Defective inlet disc, seal, or wave washer (see pages 30 and 31).
2. Missing or defective o-ring(s) at resin tank to valve connection (see FIG. 4, page 7).

WATER LEAKS FROM DRAIN HOSE (during service).

1. Defective inlet disc, seal, or wave washer.
2. Defective o-ring on inlet disc shaft.
3. Defective outlet disc, seal, or wave washer.

WATER HAS SALTY TASTE

1. House water pressure low (adjust pump, if well system).
2. Partially restricted valve drain hose, top distributor, backwash flow plug, resin tank internal riser, or bottom distributor.

WIRING SCHEMATIC

